

HOTEL

Business Review

An Exclusive Business Magazine for the Hotel Industry

Business
Effect of the Budget on Hospitality Industry

Feature

The State of Tourism

F&B

Nostalgic Flavours of Soulful Comfort Food

Design

Choosing the Right Tableware

Operations

Exhaust Systems

Wellness in, and of, Hotel Industry



VEDIC AROMA LAB™

FAMILY PERFUMERS SINCE 1850



AROMA SOLUTIONS FOR THE HOSPITALITY INDUSTRY

VEDIC AROMA LAB IS THE PREFERRED CHOICE OF INDIA'S LEADING HOSPITALITY BRANDS



Vedizer® Labs

Customized **Hand Cleaners** for in-hotel use and to give as souvenir to your Guests while Check-out.

Complete with your Brand Logo, Hotel Name and Signature Scent - Packing available 50ml, 100ml, 250ml, 500ml, 5 Litre, 25 Litre



VEDIQUE™

- Aroma Oils for Oil Diffusers
- Air Fresheners
- Garden Incense Sticks
- Floor Fragrances
- Laundry Fragrances
- Water Fountain Fragrances
- and much more!



SCO SUGANDHCO™

- Scent Branding Consultation
- Aroma Workshops
- DIY Kits for Guest Activity
- Customized Retail products for reselling in Hotel's Souvenir Shop
- Strategic Signature Scent Creation by our Master Perfumer Vishesh Vijayvergiya

Email sales@vedicaroma.in

Web www.thearomadepot.com

WhatsApp +91 95191 11233

ORGANISER



INDIA TRADE PROMOTION ORGANISATION
(A Government of India Enterprise)



**REGISTRATION
OPEN**

WITNESS THE WHO'S WHO OF
FOOD & HOSPITALITY INDUSTRY
LET'S UNVEIL
NEW BUSINESS TRENDS



36th

AAHAR

THE INTERNATIONAL FOOD & HOSPITALITY FAIR

APRIL 2021
6 | 7 | 8 | 9 | 10

PRAGATI MAIDAN, NEW DELHI

HALLS 2 | 3 | 4 | 5 (GROUND AND FIRST FLOORS)

EXHIBITION ON
FOOD PRODUCTS AND BEVERAGES
F&B EQUIPMENT
(Preparation / Processing /Packaging)
HOSPITALITY AND DÉCOR SOLUTIONS

Follow us on



Official website



Facebook



Twitter



Instagram

Supported by

Ministry of Food Processing Industries
(Govt. of India)



Agricultural & Processed Food Products
Export Development Authority (APEDA)

Associates



All India Food Processors'
Association (AIFFA)



Association of Resource
Companies for the Hospitality
Industry of India (ARCHII)



Food & Hospitality Support
Association of India
(FHSAI)



Forum of Indian Food Importers
(FIFI)



Hotel and Restaurant
Equipment Manufacturer's
Association of India (HOTREMAI)



Federation of India Food
& Hospitality Industry



Indian Confectionery Manufacturer
Association

For Registration & Other Details please visit

Corporate Website: <http://www.indiatradefair.com>

Event Website: <https://www.indiatradefair.com/aaahardelhi/>



Covid-19 has created major disruptions in the hospitality industry. People around the world are combating stress and strain due to the challenges being posed by Covid-19. The industry is now looking for opportunities to emerge from the crisis in a stronger way.

The hospitality industry sees a greater opportunity as individuals around the world focused more on health and wellbeing. Hotels offering wellness-focused hotel experience are likely to be more in demand than ever. Hotels those address the expectations of the new wellness-focused guest will be best positioned to attract bookings. But the industry faces problem due to SOPs like social distancing, strict sanitization etc. The cover story dwells upon various aspects of wellness programmes offered by hotels to ensure wellness of the guests and also the hospitality industry.

As the industry is desperate to revive, also been looking for government support to survive and recover in 2021. But the current budget has not provided any major relief for the industry. The business story finds out the effect of the budget on the future of the industry, from horse's mouth.

Now as the post-lockdown economy has slowly opened its shackles and the tourism has begun, both our domestic and inbound tourists have started exploring destinations. Feature story explains how one can explore the fabulous tourism bounty of West Bengal.

The section stories have focused on Comfort Foods in the F&B Section, Role of Tableware in foodservice under Design section and how hotels can offer touchless experience to their guest in Technology section.

HAMMER
HOTEL
Business Review
 An Exclusive Business Magazine for the Hotel Industry

Publisher cum Editor

Rajneesh Sharma
 rajneeshhammer@gmail.com

Resident Editor

Sharmila Chand (Delhi)
 Ashok Malkani (Mumbai)

Layout & Design

Hari Kumar V
 Abhishek Singh Rathore

Production Assistant

Jyoti Gupta

Advertising Sales

Delhi: Debabrata Nath, Sumesh Sharma

Director Sales

Sanjay Anand
 Mobile: +91 9811136837

Director Operations

Rajat Taneja
 Mobile: +91 9810315463

Editorial & Advertising Offices:

Delhi:

Hammer Publishers Pvt. Ltd.
 206, Samrat Bhawan,
 Ranjeet Nagar Commercial Complex, New Delhi-110008
 Phone: 91-11-25704103, 45093486, 45084903

Mumbai:

Hammer Publishers Pvt. Ltd.
 105, 1st Floor, Aarpee Centre, Gufic Compound,
 11th Road, MIDC, Near Tunga Paradise,
 Andheri (E), Mumbai-400093, India
 Phone: 91-22-28395833
 E-mail: info@hammer.co.in

© 2021 Hammer Publishers Pvt. Ltd. No part of the publication may be reproduced, stored in retrieval system, or transmitted in any form or by any means, electronic, mechanical, photocopying, recording or otherwise, without prior written permission of the publisher.

Hammer Hotel Business Review is a bi-monthly magazine, printed, edited, owned and published by Rajneesh Sharma on behalf of Hammer Publishers Pvt. Ltd., 206, Samrat Bhawan, Ranjeet Nagar Commercial Complex, New Delhi. Printed at Print Creations, C-112/3, Naraina Industrial Area, Phase-1, New Delhi.

Editorial Policy: Editorial emphasis in Hammer Hotel Business Review magazine is on educational & informational material specifically designed to assist those responsible for managing institutional Hotel business. Articles are welcome and will be published on the sole discretion of the editor.

Disclaimer: The editor and publisher believes that all information contained in this publication are correct at the time of publishing. Content published not necessarily are the opinion or view of the editor and publisher. Editor and publisher declines any responsibility for any action taken based on the information contained in this publication, including liability for error or omission.

Annual subscription rate within India is Rs. 600 and for overseas it is US \$110, for surface mail. Single issue is available for Rs. 100 in India and US \$25 for overseas. Cheques are payable to Hammer Publishers Pvt. Ltd.

HAMMER

HOTEL

Business Review

An Exclusive Business Magazine for the Hotel Industry

inside

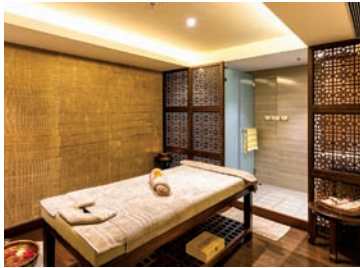

COVER STORY

Wellness in, and of, Hotel Industry

18

BUSINESS

Boost or Bust?

Effect of the Budget on Hospitality Industry

24

FEATURE

The State of Tourism

30

F&B

Nostalgic Flavours of Soulful Comfort Food

34

DESIGN

Choosing the Right Tableware

38

OPERATIONS

Exhaust Systems

42

PROPERTY

Ganga Kinare - A Riverside Boutique Hotel

44

DEPARTMENTS

Event

04

News

06

Report

14

Appointments

16

Technology

40

Housekeeping

48

Product Preview

50

Interview

52



Cover Pic Courtesy:
Sterling Holiday Resorts, Rishikesh



AAHAR 2021

April 06-10, 2021, Pragati Maidan, New Delhi

ITPO offers considerable discount on participation in AAHAR 2021 to support the industry

ITPO has announced the fresh dates for Aahar 2021. The 36th edition of Aahar 2021 will now be held during April 06-10, 2021 at Pragati Maidan, New Delhi. According to an official release by ITPO, the exhibition will be organised in accordance with the Covid19 SOPs specified by the Department of Commerce, Government of India. The Expo will be held in Halls A3 to A5 of the newly built halls of the world class International Exhibition cum Convention Centre (IECC), ITPO said.

A five day - flagship event of the India Trade Promotion Organization (ITPO), AAHAR2021 - is being offered with discounted rate of 45 per cent on participation charges to support the Indian industry. The 36th edition of the fair features emergence of India in F&B as well as hospitality services including food processing, culinary tech, retail and news innovations at Pragati Maidan, New Delhi. All exhibitors as well as business visitors will be required to strictly adhere to the COVID-19 related guidelines / SOPs issued by the relevant government authorities.

AAHAR 2021 is being organized by ITPO with support of the Ministry of Food Processing Industries, Agricultural and Processed Food Products Development Authority (APEDA) and apex industry associations, Association of Resource Companies for Hospitality Industry of India (ARCHII), Hotel and Restaurant Equipment Manufacturers Association of India (HOTREMAI), All India Food Processors Association(AIFPA), Food & Hospitality Support Association of India (FHSAI), Forum of Indian Food Importers (FIFI), Federation of Indian Food & Hospitality Industry (FIFHI).

The fair assumes tremendous significance

in light of the announced Union Budget which has a focus on promotion of agricomunity as well as tourism and MICE sectors which complements the hospitality segment. This year too, AAHAR offers an ideal opportunity for brand expansion and business networking especially when the industry has been facing tremendous challenges due to Covid-19 pandemic.

Significantly, AAHAR2021 is being organized in the halls of iconic International Exhibition-cum-Convention Centre (IECC) at Pragati Maidan, the display profile is



segregated into four categories namely, Food Products, Ingredients & Additives, F&B Equipment, House Keeping & Engineering Equipment and Bakery & Confectionary.

It is expected that the large number of trade visitors will visit Aahar 2021. These include top echelons of the Hotel and Hospitality industry including CEOs, General Managers, Executive Chefs, Executive Housekeepers, Purchase Managers, etc. Besides, senior representatives from catering industry and academic institutions, training

hotel management professionals will also visit the fair.

Besides the potential to foster business revenues, Aahar also provides an effective platform for the players across global food & beverage and hospitality industry to disseminate/gather relevant information and gauge ongoing and future trends, which can greatly benefit the participants at the fair.

Apart from the meaningful display, the fair offers an insight to operational and food safety concerns and innovations to become energy-efficient, finding budget friendly raw materials boosting productivity, while still aiming for greater profitability.

The forthcoming mega event can be the right place for importers, overseas trade delegations and Indian players in the food & beverage and hospitality space, and also for policy makers and media personnel to exchange knowledge and information.

India's food retail industry is also going through impressive growth phase. Especially, in the backdrop of the impressive growth potential of the Indian food services and food retail industry and with the revival of the Indian hospitality industry on the cards, the relevance of a mega event like Aahar simply cannot be overlooked.

Going by the emerging and futuristic trends in the Indian food & beverage and hospitality industry, we can safely assume that the forthcoming edition of Aahar is expected to grace by impressive numbers of visitors.

AAHAR is open for the business visitors from 10.00 am to 6.00 pm., daily.

For further details visit:
www.indiatradefair.com



Innovative Equipments for Effortless and Effective Cleaning

CLEAN CARE



Dry Vacs

Wet & Dry Vac

Upholstery Cleaner

High-Pressure Cleaners

FLOOR CARE



Ride on Scrubber Driers

Scrubbers & Polishers

Walk Behind Scrubber Driers

SERVO CARE



Housekeeping Trolleys

Linen Trolley

Mini Bar Trolley

AIR CARE



ULV 50

Airsteril

MOP WRINGERS



Wringer Trolleys

WASHROOM CARE



Wash room Cleaners & Sanitizers

BIO CARE



Bio Blocks

Citra Clean

CHARNOCK EQUIPMENTS PVT. LTD.

'Charnock House' #23, 8th Cross, Asheervad Colony, Horamavu, Bangalore - 560 043, India.

Call : +91-80-41651212 / 13 / 14, Fax : +91-80-41651216, Email : sales@charnock.biz www.charnock.biz

AHMEDABAD • BHOPAL • CHANDIGARH • CHENNAI • COCHIN • DELHI • GOA • HYDERABAD • JAIPUR • KOLKATA • LUDHIANA • MUMBAI • PUNE

Manufacturers of Guest Toiletries



5 Ltr. Cans for Spa Purpose

Tenzy Shave Gel 4 gm

Toiletries

Transparent Soaps

White Soaps

Modern Cosmetic India

Bawana Industrial Area, Bawana,
New Delhi-110039, India

Mobile: 9910059004, 8178885043

Email: moderncosmeticsindia12@yahoo.com

News Scan

Apeejay Surrendra Park Hotels Launches a New Brand 'Zone Connect'

Apeejay Surrendra Park Hotels Limited launches 'Zone Connect', a limited service brand under its 'Zone by The Park' portfolio. 'Zone Connect' channels its inimitable spirit and design ethos of 'Zone by The Park'. The brand has been launched with 4 'Zone Connect' hotels, all under management contract, in Coimbatore, Goa and Port Blair. The hotels are slated to open in the first half of 2021.

'Zone by The Park', the upscale social catalyst brand has had a fast recovery in the last three months (quarter 3) driven by its F&B, wedding and social events. The brand has a strong presence with 11 hotels running across the country in cities like Coimbatore, Jaipur, Kolkata, Bangalore, Jammu, Jodhpur and Chennai.

Zone Connect Coimbatore will have 55 contemporary designed rooms, an all-day dining, bar and a banquet which makes it an ideal business hotel. This is the group's second hotel in the city, after Zone by The Park Coimbatore, which was launched in 2014. Zone Connect Goa is located in bustling Bandez (north of Goa) and will house 49 rooms with an all-day dining, a bar, banquets, a pool, a spa and a salon. It is expected to open in the first quarter 2021. Zone Connect Port Blair will consist of 25 rooms, a restaurant, a bar, a banquet, a spa, and a pool. Zone Connect Tirupati with 88 rooms will have all day dining and banquets.

Vijay Dewan, Managing Director, Apeejay Surrendra Park Hotels Limited said, "We are delighted to launch Zone Connect under our social-catalyst brand, Zone by The Park. It borrows from the ethos of Zone by The Park in being interactive, creative and contemporary. We are excited to have signed three hotels so early on. Zone Connect will bridge the gap for quality accommodation in Tier II and Tier III cities and will give the hotel owners opportunity to grow their business with a reliable and thriving brand."



Vijay Dewan

Ginger Signs its Milestone 75th Hotel

Ginger announces the milestone of its 75th hotel with the signing of the brand's second hotel in Aurangabad, in the state of Maharashtra. This signing is in line with Ginger's growth strategy of increasing the brand's presence in key commercial hubs and state capitals of India. The hotel will be designed around the brand's lean luxe philosophy of offering a vibrant, contemporary and seamless hospitality experience to its guests.

Commenting on the signing, Ms. Deepika Rao, Managing Director & Chief Executive Officer, Ginger Hotels, said, "This is a proud moment for us. Our guests and the investor community have shown great confidence in the new lean

luxe offering, which has helped us achieve this key milestone. The journey of the brand has been very exciting. We are very happy to partner with the Asawa Brothers Group for the on boarding of this landmark 75th hotel in Aurangabad."

Ginger Aurangabad will be located near Jalgaon Road, in the central business district of the city, and a short drive from the airport. The hotel will feature 64 rooms, an all-day diner, a meeting room and a fitness centre. This will be a fully fitted lease with the Asawa Brothers Group. Aurangabad is a popular tourist hub with UNESCO World Heritage Sites like the Ajanta and Ellora caves. This city is also a major silk and cotton textile producer for the country.





You make it happen

INNOVATIVE IDEAS. INVEST IN THE FUTURE



KORE GENERATION: ROBUST DESIGN AND AN IMPECCABLE LEVEL OF CLEANLINESS



FROM ONE PROFESSIONAL TO ANOTHER

COMBI OVEN



Fagor Industrial S. Coop.

Santxolopetegi auzoa, 22
20560 Oñati, Gipuzkoa (España)

T. (+34) 943 71 80 30
F. (+34) 943 71 81 81

info@fagorindustrial.com
www.fagorindustrial.com

F-89/8, 1st & 2nd Floor, Okhla Industrial Area Phase-1, New Delhi 110020 (India) T. +91 1140 649 001 M. +91 9313433186 Email: h.bist@fagorindustrial.com

HRAWI Continues FSSAI's FoSTaC Programme in 2021



The Hotel and Restaurant Association of Western India (HRAWI) in association with the Food Safety and Standards

Authority of India (FSSAI) has resumed conducting the Online Food Safety Supervisory Training in Advance Catering (FoSTaC) programme for the year 2021.

"The FSSAI is taking extra efforts to prioritize education on food safety and handling SOPs amongst hospitality professionals and the HRAWI wants its members to equip themselves with this knowledge. Conducting such trainings has become all the more critical during the Corona virus pandemic. Not only will it ensure that hospitality professionals are fully aware of the nuances in food handling and safety, but it will also help in building customer confidence. This training session was conducted virtually and we were pleasantly surprised to see a good turn-up. We are glad to know that hoteliers and restaurateurs see value in the programme," says Sherry Bhatia, President, HRAWI.

The HRAWI has successfully trained and certified over 3000 hospitality professionals across India's Western region

Pride Group of Hotels' New Properties in Gujarat

Pride Group of Hotels has announced its expansion in the state of Gujarat with the signing of a new hotel in Surendranagar. This new property is branded under Pride Biznotele. Pride Hotels are already operating hotels in Ahmedabad, Rajkot, Vadodara and Anand.

The group has also tied up with Alfolik Constructions to launch Pride Hotel Bharuch in the state of Gujarat. In its first phase of



Satyen Jain
CEO - Pride Hotels Ltd.

opening, Pride Hotel Bharuch will feature 85 plush guest rooms besides 2 restaurants that will offer local and global cuisine. The hotel will also have 2 banquets that offer the ideal venue for MICE.

Commenting on the development, Atul Upadhyay- VP Operations, Pride Hotels Ltd., said "In the last few months, things have accelerated positively for the hospitality market in Gujarat. Surendranagar too is witnessing good economic & industrial growth and our group is proud to be part of this expansion at the right time. We are delighted to further expand our presence in Gujarat with the Pride Hotel Bharuch. We intend to establish our brand further in the region while assuring a comfortable work or leisure stay for our guests."

With its presence around 20 locations across India, Pride Group of Hotels boasts of 2500+ Rooms, 52 Restaurants and 73 Banquets and Conference Halls, reinforcing itself as the one-stop destination for MICE.

Pride Hotels partners with Indian Railways (IRCTC) to deliver a safe stay

The Pride Group of Hotels has announced its partnership with the Indian Railway Catering and Tourism Corporation (IRCTC) to deliver a safe and luxurious stay for rail travellers. Under this association, rail passengers will now be able to book their accommodation with their train tickets.

Through this partnership The Pride Group of Hotels will offer a hassle-free platform for Indian Railways passengers to book hotel rooms in any of the desired Pride properties located across the country. Apart from the stay, the Pride Hotel will also provide the guests with five-star amenities, including air-conditioning facilities, Wi-Fi access and 24-hour customer service support.

Commenting on the association, Amit Sidana, VP Sales & Marketing at Pride Group of Hotels says, "With this association, IRCTC customers will have ready access to the accommodation at the Pride Properties across the country. This initiative will help the travellers in preparing their itinerary through a one-stop window from booking their tickets to accommodation."

Keeping the present circumstances in mind and as a part of the 'New Normal', the Pride Group has also launched the 'Pride Safety Assurance' initiative.

Protector[®]

SHAVING CREAM & SHAVING GEL

A Product from:
INFINITY HYGIENE CARE

Experience Luxury

THAT TRANSCENDS BEYOND WALLS



BRAID & ROPE FURNITURE



WICKER HANDWOVEN FURNITURE



TEAK WOOD & METAL FURNITURE

*T&C Apply

Loom Crafts India's Finest Range of All Weather Outdoor Furniture

EXCLUSIVE RANGE OF

DINING, SITTING & BAR STOOLS • SOFAS & RECLINERS • SUN-LOUNGERS • OUTDOOR ACCESSORIES



Head Office & Manufacturing Unit:

A - 7/98 & 99 South Side G.T. Road Industrial Area, Ghaziabad - 201009, UP, India. • Contact: 8448440556 • Follow us at

DELHI • LUCKNOW • BENGALURU • CHENNAI • BHUBANESWAR • HYDERABAD

For more information & detailed catalogues visit www.loomcrafts.com or e-mail us at info@loomcrafts.com

L.P.G./P.N.G. Pipe Line Installations
 Kitchen Ventilation System's, Exhaust Hood, Scrubbers,
 Air Washer & Ducting Work(HVAC) etc.
 LPG/PNG Leakage Detection Systems

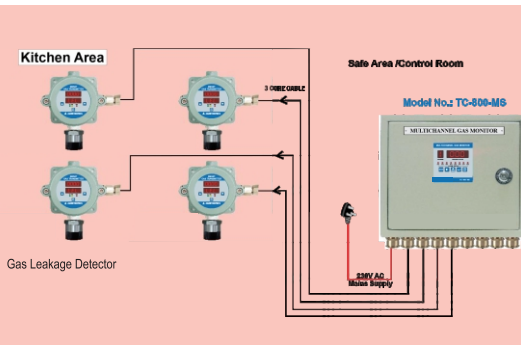

- Kitchen exhaust system including designing of air ducting, size of exhaust hood, size of ventilation blower and CFM.
- Kitchen fresh air system including designing of duct size and CFM of air washer system.
- LP Gas System including Gas Bank

R.R. Sales Corporation

Office: Plot No. 1, GTK Road,
 Near Aryabhata Flyover, Delhi-110033
 Mobile: 9310336756
 E-mail: tarun.rrsalescorporation@gmail.com

Express Group of Hotels Acquires Cambay Hotels

Gujarat's 4-star hotel chain, Express Group of Hotels, has recently acquired seven of Neesa Leisure Ltd. (NLL) operated Cambay Hotels. Presently, the Express Group of Hotels owns and operates three premium hotel properties in the State, two in Vadodara and one in Jamnagar. With the recent acquisition, the Express Group adds over 800 keys to its existing portfolio of 376 rooms.



Hiren Gandhi



Nirav Gandhi

The new properties are located at Gandhinagar and Ahmedabad in Gujarat and also at Neemrana, Udaipur and Jaipur in the State of Rajasthan. Express Group of Hotels is awaiting the approval of the National Company Law Tribunal (NCLT), Ahmedabad for formally taking over the reins of Cambay Hotels.

"The Express Group of Hotels is expanding and it's exciting times for the company. At present, we are one of the few premium hotel chains in Gujarat. With the new addition, we not only will increase our offerings in Gujarat but will also venture into Rajasthan, a new market for us. Cambay Hotels has been here for over four decades, so essentially we are inheriting a legacy. We are awaiting the approval of the NCLT and are confident of a positive outcome, soon," says Nirav Gandhi, Owner, Express Group of Hotels.

Hiren Gandhi, Director, Express Group of Hotels, adds, "A new investment during one of the toughest times in the Hospitality business is nothing short of miracle. It is also a testimony to the India growth story of which we will see more in the coming years. The Travel and Tourism industry is one of the hardest hit by the COVID-19 pandemic and a positive news is sign of good times ahead for Hospitality."

Signum Hotels Expand Footprint in Europe

Signum Hotels & Resorts continues to strengthen its presence in Europe with another hotel signing. A new-build Signum Adrenaline Park Tara is scheduled to open in Serbia in April 2021 as the latest addition to the company's premium lifestyle collection of exceptional hotels. The hotel will be the group's first hotel in Eastern Europe, strengthening the company's brand presence in this region.

The 40-room hotel will have a restaurant, meeting space for 100 guests and outdoor parking. Travelers and shoppers will be delighted by the central location since it is just 200 meters from the Tara River, 10 kms from airport and only 200 meters from the railway station. Signum Adrenaline Park Tara is truly one-of-a-kind, distilling the best of its location through interior design, exceptional guest amenities and the expertise of its people.

Announcing the signing, Mehul Sharma, Founder & CEO - Signum Hotels & Resorts said, 'we are excited to mark our presence in a new region that holds great potential for tourism. This new hotel signing is in line with our strategy to expand across exceptional destinations globally. We are looking forward to the hotel launch by end-April 2021.'

Milan Popovich, Owner - Adrenaline Park commented, 'we are pleased to collaborate with Signum hotels for this venture. It will be our outmost delight to offer heart-warming hospitality to travellers visiting Serbia for business or leisure.'

Signum Hotels & Resorts is a new-age hotel management firm offering specialized services to hotels across the Asia Pacific region. It offers exceptional service provided by a diverse team with a remarkable combined experience across varied hospitality verticals. The emerging hospitality company has already made its mark with 12 hotels across India and 18 service apartments in London and vies to manage 1000+ keys by 2021.



washes from 10 kg to
110 kg

Bulk laundry solutions for total peace of mind
COMMERCIAL LAUNDRY SOLUTIONS



SMART
SAVE

- Impeccable hygiene
- Water savings
- Manpower savings
- Quick turnaround
- Higher productivity



Commercial Laundry range

Commercial Dishwashing range

24x7 Service across India

Commercial essentials

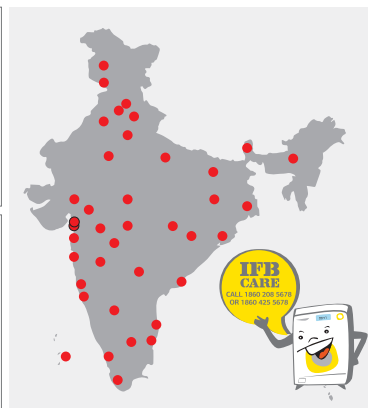

The Quorum to Launch in Mumbai

The Quorum, a lifestyle club that opened in Gurgaon in 2018, has announced the launch of its second club, in Mumbai. With an anticipated opening date in April 2021, The Quorum in Mumbai aims to introduce and further extend its unique blend of hospitality and philosophy of being community-led, content-driven, design-focused and experiential, to a discerning Mumbai audience.

Conceptualized with a global sensibility by Vivek Narain (Founder & CEO) and Sonya Jehan (Co-Founder & Creative Director), The Quorum's launch in Mumbai will be perfectly timed to address the question on the mind of many – what does the future of office-going, socialising, and events look like, in the new normal?

Says Narain, "A private club like The Quorum has been designed as the 'quintessential third space' – a home away from home, a place of work away from the office. In a time of continuing uncertainty, The Quorum has a unique social contract with its members, providing a predictable and safer space be it for business or for leisure."

The Quorum will open its doors in Lower Parel's One World Center, owned by Nucleus Office Parks, a subsidiary of The Blackstone Group, spanning two floors, within 56,000 sq. ft. of space. The launch of the Mumbai club marks the start of The Quorum's expansion plans in the country.



BONNE[®]
TOOTH BRUSH

ECO Friendly Compostable & Biodegradable Toothbrush

Laxmi Brush Company
A Quality Brush from Laxmi Brush Company

Lemon Tree Hotels Announces New Properties

Lemon Tree Hotels Ltd. launches its second property in Vijayawada

Lemon Tree Hotels Limited, through its management subsidiary Carnation Hotels Pvt. Ltd., announced the opening of Lemon Tree Premier, Vijayawada. This is the second property of the brand in the third largest city of Andhra Pradesh. The strategic location of the hotel offers multiple options to experience the city's tradition, architecture and ethos. The hotel features 122 well-appointed rooms and suites that feature Kalamkari art and intricate sculptures inspired by the traditional art forms of Vijayawada, with modern amenities and facilities.



Complementing the stay are a vibrant atrium lobby, a multi-cuisine coffee shop – Citrus Café, an award winning pan-Asian restaurant – Republic of Noodles and a hip recreation bar – Slounge. The hotel also features expansive banquet spaces and conference facilities, including large conference and banquet halls to meet discerning guests' business needs and event requirements. Recreational facilities include a rejuvenating spa – Fresco, a well-equipped fitness center and a refreshing swimming pool and pool deck – Serenity where guests can bask under the sun overlooking the city and refresh themselves with an array of rejuvenating drinks and bites.

The hotel's prominent location also offers easy access to Vijayawada's key attractions such as the ornate Kanaka Durga Temple, nestled on the Indrakeeladri Hill, the Undavalli Caves featuring ancient rock-cut temples, formed out of a single granite block, and the Bhavani Island on the Krishna River.

Lemon Tree Hotels Ltd. debuts in Aligarh

Lemon Tree Hotels Limited, through its management subsidiary Carnation Hotels Pvt. Ltd., announced the opening of the 68 key hotel–Lemon Tree Hotel, Aligarh. This is the first property of the brand in this historic city, located at a short distance from many tourist destinations such as Aligarh Fort, Khereshwar Temple and Naqvi Park.



The hotel features 68 well-appointed rooms and suites, which combine understated elegance and old world charm with modern amenities and facilities. The contemporary interiors and the inspiring artwork of this hotel make for a setting that is refreshing, while still reflecting a touch of the city's heritage in the artefacts.

Complementing the stay are a multi-cuisine coffee shop – Citrus Café, an Indian speciality restaurant - Kebab Theater and a hip recreation bar – Slounge. There are also banqueting and conferencing facilities to meet discerning guests' business needs. Recreational facilities at the hotel include a rejuvenating spa – Fresco, a well-equipped fitness center and a refreshing swimming pool.

We Know what productivity means to you.
A LOT !

MEHTA
FURNISHERS

www.mehtafurnishers.com

Inspire ▶ Experience ▶ Perform



Strolleys & Trolleys || Furniture || Baskets || Accessories

No.1, Chotey Lal Park, Main Najafgarh Road, Opp. Kirti Nagar, New Delhi-110015
 Tel. : +91-11-25442200, 25412250, Mobile : +91-9811114668 E-mail : mehtafur@gmail.com

• Practical designs • Protective sleeves to reduce scratching • Superb Quality • Option of Pneumatic wheels for transit vibration reduction



Brand Welcomhotel forays into Himachal Pradesh with their first property in the State

Welcomhotel has launched its first property in Himachal Pradesh - 'Welcomhotel Shimla'. Tucked away in an unexplored village with experiential stays, lush green expanse and breathtaking views of the hills, Welcomhotel Shimla is the ideal getaway destination to reconnect with Nature. As one leaves behind the bustling streets of Shimla city center and drives uphill, the tranquil town of Mashobra is only half an hour away and is a beautiful haven for hikers.

Blessed with pristine beauty, natural streams, bountiful orchards and lush green coniferous forests, Mashobra is a quaint, serene destination that attracts nature lovers, peace mongers, thrill seekers and history buffs. With a 25-hour check-in / check-out, all Welcomhotels give you that additional hour to explore more or simply bask in the warmth of your hotel.

Design

Welcomhotel Shimla offers a great view of the green splendor with all 47 rooms and suites overlooking the picturesque Mashobra valley. The views are panoramic and unparalleled. The building is laid out to receive maximum natural light and all guest room windows are designed at very specific angles to receive incessant sunlight from dusk to dawn.

The design philosophy of the hotel is modern with minute elements of the old world

charm and has all the makings of a "Green" hotel with commitment to sustainability - Ecological, Social and Economic. ITC Hotels' specialized design team was mindful that the authenticity of the land was maintained. Aligning with ITC Hotels' Responsible Luxury philosophy of conservation of resources, all grey water is treated in-house and used for horticulture. Non-carcinogenic wooden materials are used around the property and intelligent controls have been built in the elevators to maximize movement efficiency.

Speaking on the launch Nakul Anand, Executive Director - ITC Ltd. said, "With domestic travel and wellness experiences regaining popularity, we believe it is the perfect time to launch our latest Welcomhotel outpost in "Devbhoomi" Himachal Pradesh. With stunning 360° mountain views and striking architectural and interior design, we aim to attract discerning leisure and business travelers with our heightened safety measures in place and the quintessential Welcomhotel hospitality at the forefront."

Food & Beverage

Both ITC Hotels and Brand Welcomhotel is synonymous with a strong culinary philosophy, legendary Master Chefs, palate pleasing food and exotic beverages. Welcomhotel Shimla offers two superlative food and beverage outlets.

WelcomCafe Cedar - the all-day dining restaurant offers fresh seasonal specialties

from the region along with a holistic menu with signature Indian and international dishes. Guests will be in for a culinary treat with WelcomSthalika, an assortment of popular regional dishes that come laid out on a single platter hence strengthening the virtue of Vocal for Local that the brand truly believes in. The ingredients are seasonal and locally sourced, supporting the farming community of the neighbourhood. The Swizzle bar overlooking the coniferous flora serves signature cocktails and has the most premium wine lists on offer.

With 3186 sq.ft spacious, seamless, indoor banquet spaces and a huge 3477 sq.ft outdoor venue called the "Sunset Garden", surrounded by the majestic Himalayan range, the hotel can host both social and corporate events with élan. The in-house event managers will ensure that all events are personalized, customized and follow the current safety and hygiene protocols.

Activities

With wellness being an intricate part of the brand's ethos, the soon to open 'K by Kaya Kalp' the spa will offer signature therapies, holistic rituals and personalized wellness experiences like Yoga and Zumba.

Perfect for a leisurely family getaway in the lap of snowcapped mountains, the hotel has indoor and outdoor activities like chess, kids' play corner and guided local tours. The outdoor golf putting area is soon to open.

Welcomhotel Shimla offers enriching experiences for its guests. Adding to great experiences is bird watching with the assistance of naturalist or a heritage walk along with a local historian. Enjoy cycling within the Shimla Wildlife Sanctuary or picnics & camping in the greens. For the young adults "Ollies Club" offers a range of activities like archery, skittle, croquet, badminton, table tennis, pool, board games, darts and more.

Located strategically in close proximity to the golf course and mall road, there are a plethora of sightseeing options to choose from. Enjoy tranquil natural walks to Craignano Natural Trail, Mashobra to Kalyani Helipad, and Mashobra Valley Trail & Shalli hike under professional guidance. For the adventure aficionados who travel to Narkanda, Hatu and Lahaul-Spiti, Welcomhotel Shimla makes for an ideal stop on the way.

With domestic travel enjoying a steady growth and rediscovered love for local attractions, guests will get to experience the rural charms of a Himachali village surrounded by thick canopies of fragrant Cedar trees. It's



the perfect break from the mundane city life, in the untouched wilderness, amidst nature. It's truly your home in the hills.

For today's experience driven traveller, Brand Welcomhotel offers immersive and enriching experiences with a window to the city's local culture. From curated experiences that enhance the leisure trip to those that maximize the efficiency of business stays, each Welcomhotel is designed to add value to the new-age traveller.

With the enduring Namaste as the symbol of its brand experience, ITC Hotels is one of India's leading luxury hotel chains offering comprehensive hospitality solutions through more than 100 hotels in over 70 destinations in the country. ITC Hotels is committed to delivering luxury experiences with sustainable practices embedded in the process - an endeavor which has manifested in the coveted LEED® Platinum rating for all its luxury hotels.



Luxury Linen & Bedding



We Make World Class Hospitality Linen

Our Specialisation :

- **Luxury White Towels** • **Spa Towels** • **Luxurious Bath Rugs** • **Mattress Protector** • **Duvet-Comforters**

Manufacturers, Suppliers & Exporters

ARS Global Textiles

Reg. Office: Plot No F1/16, Sector-3, Eldeco Estate One, Huda Sector - 40, Panipat-132103

Ph.: +91-180-2576636, 9729036699 **E-mail:** arsglobaltextiles@gmail.com, ravinderruhal10@gmail.com

Factory: 11th Mile Stone, Kohand Assandh Road, Distt. Karnal-132040



Sharad Puri

Sheraton Grand Bengaluru Whitefield Hotel & Convention Center and Aloft Bengaluru Cessna Business Park has appointed Sharad Puri as the new Cluster General Manager. An industry veteran with an exemplary track record, Sharad brings with him an amalgamation of knowledge, experience and learning of over 25 years in the luxury hotels business. Sharad began his journey with The Oberoi, Mumbai and the Oberoi Towers, Mumbai during 1995-2000 where he held various positions in the Rooms Division. He continued his association with the group joining The Oberoi Grand, Kolkata in 2000 till 2004. Prior to joining JW Marriott Mumbai Juhu as the General Manager in late 2017, Sharad spent his time from 2004 to 2017 with established brands including the Trident Hyderabad, Trident Chennai and Hilton Towers, Mumbai.



Nikita Ramchandani

Nikita Ramchandani has been appointed as the General Manager of the JW Marriott Mumbai Juhu – the flagship property of JW Marriott hotels in India. Nikita has previously led the Operations discipline for the 135-hotels Marriott International portfolio as the Senior Area Director of Operations where she was responsible for setting the roadmap for new openings, talent development, guest experiences

and F&B growth. With over 20 years of experience in the industry, Nikita's astute business and leadership skills have seen her take strides across her career graph with different challenges and roles across the hospitality landscape.

She has previously been associated with esteemed brands such as Four Seasons Hotels and Resorts (Mumbai and Baltimore) and ITC Maratha – A Luxury Collection. In her new role as General Manager of the JW Marriott Mumbai Juhu, Nikita envisions a stellar roadmap for the hotel's positioning within the hospitality landscape.

Shiv Bose

Sheraton Grand Chennai Resort & Spa has appointed Shiv Bose as the General Manager of the property. He is a passionate and driven professional with almost two



decades of illustrious experience in the hospitality industry. In his role, Shiv will be spearheading the team and developing the hotel's operations to deliver stellar service standards.

Prior to joining Sheraton Grand Chennai Resort & Spa, Shiv was the General Manager at Courtyard by Marriott Bengaluru Hebbal. He has been the General Manager at Le Meridien, Nagpur for over two years and was also associated with Starwood Hotels and Resorts and East India Hotels.

Management Changes at IHCL

Indian Hotels Company (IHCL), South Asia's largest hospitality company, today announced organizational leadership changes. Gaurav Pokhariyal has been appointed as Senior Vice President & Global Head – Human Resources and Parveen Chander Kumar has been appointed as Senior Vice President – Sales & Marketing. Gaurav and Parveen will be taking over these leadership roles from industry and IHCL stalwarts, Dr. P V Murthy and Ms. Renu Basu, respectively, as they retire after a successful stint at the Company.



Gaurav Pokhariyal

Speaking about these developments, Puneet Chhatwal, Managing Director and Chief Executive Officer, IHCL stated, "We are delighted to welcome Gaurav and Parveen on board and believe that their expertise will help IHCL continue on its journey of excellence. These developments are in line with our commitment to recognize and cultivate talent from within the organization. We also thank Renu Basu and Dr. Murthy for their invaluable contributions, and are positive that we will continue to benefit from their knowledge and experience in the future as well."

In their new roles, Gaurav and Parveen will join the Executive Committee (ExCom) of IHCL.

Gaurav brings with him three decades years of rich experience in Operations and has held a number of critical roles, the most recent being heading operations for key markets in the Northern region. Gaurav is known for his decision making ability, commitment and passion towards his work.

With three decades of expertise in Operations, Parveen has successfully led key positions across marquee IHCL hotels, including those in the Western region. A formidable executer, his customer-centric focus is one of his key strengths.

Both, Gaurav and Parveen are alumni of the Glion Institute of Higher Education, Switzerland, and IHM Pusa. In their new roles, Gaurav and Parveen will be responsible for executing IHCL's strategy for long term growth whilst further strengthening the Company's market and brand leadership position.



Parveen Chander Kumar

Vegetable Washer



Tilting

Non Tilting

The traditional way of washing fruit, vegetable, meat, fish and frozen food is both time consuming and usually does not guarantee the removal of all unwanted insects and dirt. The problem of washing large quantities without damaging the structure and quality of vegetables and fruits is easily solved with our vegetable washer. This machine is designed to aid removal of dirt, wax and pesticides from the fruits and vegetables before they are enter your kitchen.

Jewel Case Display Cabinet

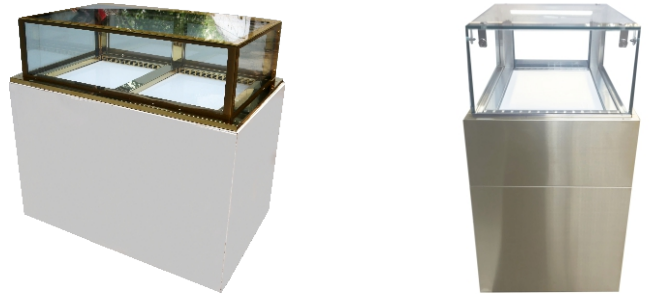

2 Drawer Cabinet (Drop-In)

1 Drawer Cabinet

RANS present its latest range of elegant front of the house jewel case display cabinets. Available in both free standing and drop-in models. Jewel cases can be customised in numerous colors of designer stainless steel to match the interior color theme. A must have for all upmarket bakery and confectionary stores.

Pizza Oven



Stone Hearth Ovens

Stone Hearth Ovens

Designed to bake and roast a wide variety of food, they are built to last and are capable of continuous duty 24 hours a day. This together with their user-friendliness and very smart appearance, makes them the ideal solution for restaurants and front-of-shop applications where safe, efficient, unobtrusive equipment is needed.

Salamander



Brownie

Box

RANS salamander grills are known and used by the kitchen chefs all around India. Equipped with specially designed tubular air heater it assures perfect cooking results. Our salamanders are equipped with two cooking areas - both can be used independently from each other. With the RANS salamander grills you can grill, cook "au gratin", glaze, caramelize and make crispy food in no time. It is reliable, flexible and easy to use.

Holding Cabinet



Cold Food Holding Cabinet

Hot Food Holding Cabinet

Our durable holding and transport food cabinets are constructed in full stainless steel with best of the features your restaurant and commercial operations may require. Our hot holding cabinets ensure food remains hot and safe for upto 4 hours without losing its moisture. Ideal for banquets, restaurants, coffee shops and cloud kitchens.

Bulk Steamer



Electric / Gas Operated Models

Commercial steamers are designed for new generation of kitchens. They are simple to use, having complete robust S.S construction and energy efficient. They are designed for schools, factory, hotel, banquet kitchens and restaurant. Ideal for steaming rice, vegetables, Idly, fish etc.

RANS TECHNOCRATS (INDIA) PVT. LTD.

An ISO 9001 : 2008 Company

201, Samrat Bhawan, Ranjeet Nagar Commercial Complex, New Delhi-110008

Ph.: +91-11 45189999 (30 Lines) Fax: +91-11 45189911 E-mail: info@ransindia.com, Website: www.ransindia.com

Factory: Plot 159, Sector 6, IMT Manesar, Gurgaon, Haryana-122050 Ph.: 0124-2290060

Wellness in, and of, Hotel Industry



Researchers at The Lancet Medical Journal had, in 2009, defined health as ‘the ability of a body to adapt to new threats and infirmities’. Now, 12 year later, this discovery becomes more relevant as people all over the globe are combating stress and strain due to the challenges being posed by Covid-19. People are in dire need of relaxation and wellness programmes offered by hotels in their spas and gyms. But these have posed problems for the hospitality industry, due to SOPs like social distancing, strict sanitization, et al. **Ashok Malkani** examines all aspects of wellness programmes in hotels to ensure not only the mental and physical fitness of the guests but also the wellness of the hospitality industry.

Wellness tourism was one of the fastest growing segment in the pre-COVID era. Last year has, however, been a period of stress for everyone across the globe. Coronavirus has upended almost all aspects of life and has heightened physical as well as mental health concerns for most people. Due to this, many people are now, since the pandemic has subsided to some extent, desirous of taking wellness trips to renew their mental, spiritual and physical wellbeing.

Though there have been some relaxations in the restrictions that had been imposed when the pandemic was at its peak some SOPs like social distancing still exist in most parts of the country, making it slightly difficult for operating gyms and spas to their full capacity.

As far as wellness is concerned, the tourism ministry of India is planning to position the country as the wellness and Ayurveda hub, globally. It may be mentioned that the country, post-COVID, was one of the most sought-after wellness tourism destinations in the world, due to its wellness practices such as Yoga and Ayurveda that focus on holistic health and well-being.

Wellness tourism is, due to the Ministry's plan for promoting it, thus receiving a boost. Also, with lockdown and social distancing restrictions easing across the globe, hotels are all making plans to attract the tourists. Different hotels are adopting various methods to attract wellness enthusiasts.

Ather Raza, Director of Operations, Sheraton Grand Chennai Resort & Spa, states, "As far as our hotel is concerned we have always been promoting wellness in our resort. We are equipped with state-of-the-art fitness center which is powered by Sheraton Fitness. We follow & maintain Sheraton Fitness standards that our guests love and often enjoy their time at the hotel's Fitness center."

He added, "COVID-19 has left a big impact & gap for us to fill, particularly in the hospitality industry. With an increasing focus on health and wellbeing, it is important for us to re-evaluate our offerings and cater to the needs of our guests. Presenting a relaxing, restoring and wellness-focused hotel experience is what our visitors will truly value now more than ever before. Curating spa services that boost immunity and overall wellbeing, providing outdoor activities and organic experiences, offering nutritional menus, and promoting self-care experiences



are likely to draw attention of travelers.

"COVID-19 has no doubt created global disruption, particularly in the hospitality industry. Yet, with change comes opportunity, and the chance to re-evaluate how we can emerge from the crisis stronger and more resilient."

Allan Rodrigues, Director of Rooms, The Resort Mumbai, disclosed, "This year we are going to focus on creating all round wellness packages that will include relaxing wellness treatments, healthy Sattvik food, yoga and meditation courses for a de-stressed holistic wellness experience.

"To make our guest relaxed and free from the stress caused by Covid-19, we have designed our space in a very warm and welcoming way along with quaint lighting, soothing aromas and calming music. By doing this our guests are able to relax their minds off from the virus as soon as they enter our space."

Gaurav Sinha, Director of Operations, JW Marriott Hotel Bengaluru, says, "We have always believed in overall wellness. The hotel has gone beyond its state-of-the-art health facilities and wellness centers to cater to a healthier way of life. The hotel is fortunate to share boundaries with Cubbon Park, we have utilized this benefit to promote yoga sessions and fitness sessions outside the four walls of the hotel."

He added, "The hospitality industry has always offered wellness programs to ensure overall wellbeing and rejuvenation of the soul. During the post-COVID period, I believe, wellness resorts will possibly focus on mental wellness therapies in addition to the regular therapies. Collaborations with institutes

which work towards mental wellbeing is a possibility."

Social Distancing

The stress that is being experienced in this pandemic has made people take up exercise on regular basis. The hotels have to meet not only the challenge of ensuring that the guests get their daily dose of exercise but that social distancing is maintained at all times – even in the spas. This would indeed be a difficult task for the hotels! Would the hotels be able to provide guests with the exercise and the wellness they desire?

Ather avers, "Carefully curating health and wellness programs to support the wellness journeys of our guests is our focus. The hotel has come up with several 30 to 90 minutes outdoor exercise packages which are helping our guests to stay healthy whilst in the serenity of nature. The exercises involve a lot of stress buster workouts & Yoga to enhance and ensure the health and wellbeing of guests in any significant way. We also have a well-equipped spa that offers personalized spa programmes and wellness immersions to rejuvenate our guests.

"We follow all the norms of Marriott's Commitment to Clean & maintaining social distancing is one of its pillars. We educate our guests through pre-arrival emails, hotel videos, signages & in personal interactions. Spa facilities are also providing no-contact treatments to avoid any direct interaction between guests and therapists. Treatments such as energy healing and sound baths are also gaining popularity as these cut out direct contact completely."

Gaurav claims, "Hotels have always had



Allan Rodrigues



Ather Raza



Gaurav Sinha



Neha Chhabra

the advantage of well-equipped gymnasiums, multi-purpose swimming pools and spas. The industry has taken appropriate measures to ensure the demand is met with social distancing measures. At JW Marriott, Bengaluru we have fitness and wellness packages which offer unlimited access to the hotel health club, therapy sessions and swimming pool. Social distancing measures, pre-defined time slots and capacity control are some measures taken to serve this demand keeping in mind the pandemic."

He adds, "Social distancing measures have been effectively incorporated through capacity control, limited machinery and pre-defined time slots. Sanitizing measures are critical to ensure a safe space and must be given utmost importance."

Allan disclosed, "To enable our guests to overcome the stress we offer our regular guests memberships to use our gym and spa as per their convenience. Here we take utmost care and follow strict regulations on cleanliness, hygiene and sanitation standards.

He adds, "To maintain social distancing, we have limited our spa staff, we are only taking pre-booked appointments to avoid gathering of guests at the spa reception. All our staff members have masks on at all times, we request all guests also to have their masks on at all times. We try and avoid couple therapies as that equals to having four persons in one room (however, couple therapies are undertaken keeping the guest's willingness in mind)."

Neha Chhabra, General Manager, Courtyard By Marriott Bengaluru Hebbal, however maintains that spa is a high touch service and social distancing during actual therapy is a misnomer. "However," she adds, "at our hotel we have screening touch points and stringent SOPs for our service delivery teams. Strict sanitization protocols for physical infrastructure are followed. Having robust laundry system, thermal checks & history forms of guests are some of the ways in which safety standards can be elevated."

Success in the Post-COVID Period

Wellness tourism has been one of the elements that have boosted tourist industry in India. The government, over the past few years, has implemented various incentives to promote this segment. It has also set up a ministry of AYUSH. But since wellness is not just Ayurveda and Yoga the hospitality industry has to provide wellness to satiate

desires of international tourists.

So what are the considerations that the hotels are likely to take for the success of their spa in the post corona virus period? Would it involve refurbishing the spa?

Ather asserts, "As spas adjust to the new standards and expectations post-covid, it is important to ensure that topmost health and hygiene protocols are followed while also providing a peaceful solace for guests to unwind. Spas must clean and sanitize treatment rooms, facilities, and all equipment between each appointment, hosting a limited entry of guests while maintaining social distancing, avoid any high-touch items and deep cleaning all surfaces, while following enhanced protocols around disposable items.

"As far as refurbishing of the spa is concerned, our property, Sheraton Grand Chennai Resort & Spa, is fairly new and thus our spa and fitness facilities are also new. I think more than refurbishment we need to focus on what we are offering to our guests & it should have a value for the money spent."

Neha asserts that the success of a spa – particularly post corona virus – depends on its focus on health and hygiene, along with communication of the same to the potential guest.

Speaking on refurbishing of the spa she avers, "More than revamping the physical infrastructure, the wellness offering from spas need to be re-modelled. Ayurveda guides traditional Indian philosophy of wellness, which is not an interventional – one-hour therapy. It is a way of life – how we eat, sleep, work, and take care of ourselves. Tattva Spa, at Courtyard By Marriott Bengaluru Hebbal, has worked on taking inspirations from the depth of knowledge in Ayurveda and modelled it to suit the contemporary lifestyles of our consumers. Immunity boosting services and holistic spa programmes have been developed to help consumers lead healthy lives."

Allan declares, "Since we all have gone through over six months of stress, work from home aches and pains, reduced physical activities, spending relaxation time in a spa is a relief that guests need. In order to provide continuous uninterrupted spa services to our guests we are making sure we:

- Sanitize the space every two hours
- Sanitize the space after every use
- Maintain cleanliness, hygiene and sanitization standards as per WHO in our spa as well as with all our staff."



Platinum Bed[®]

For perfect sleep

Premium Mattresses & Accessories

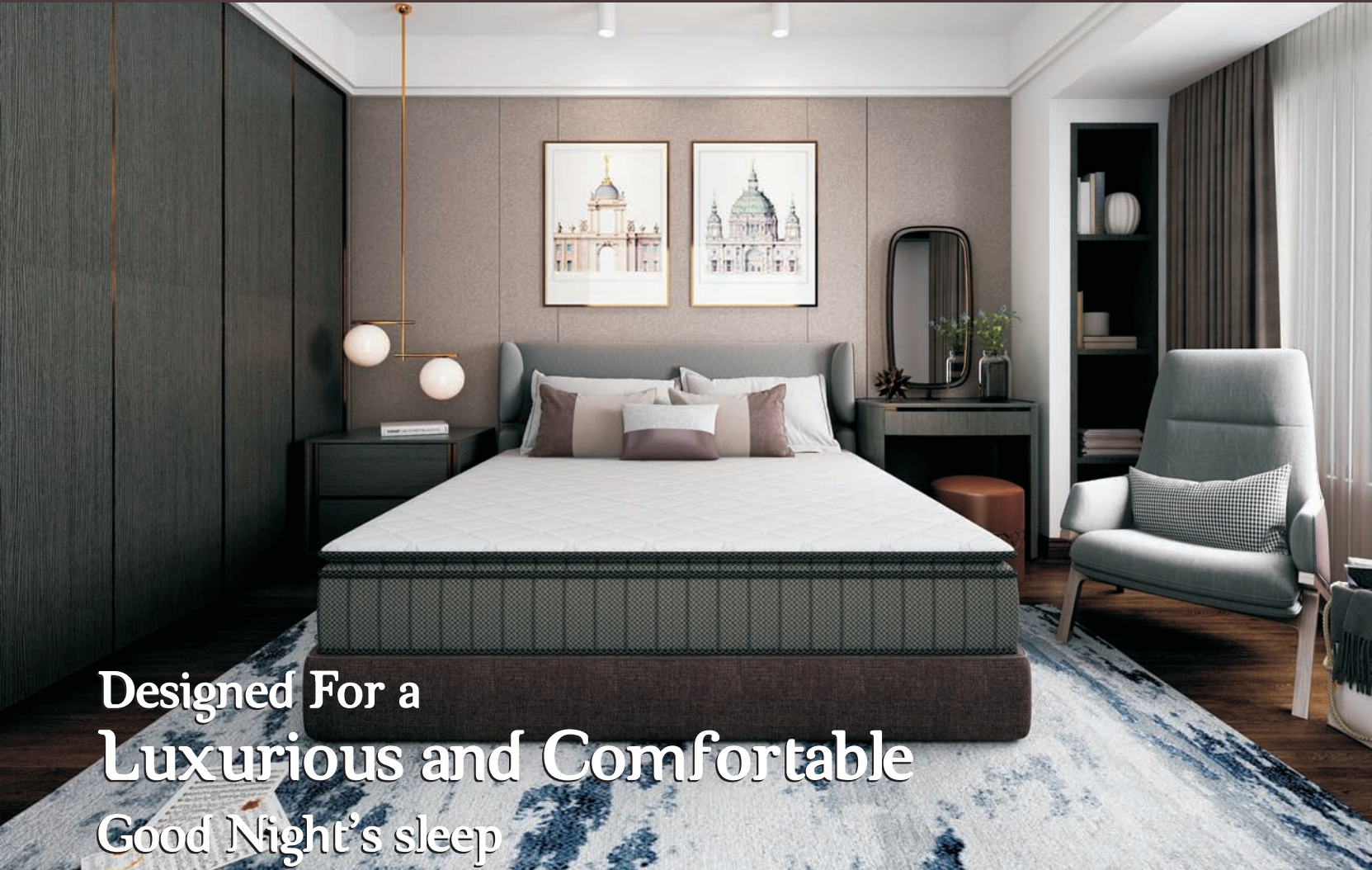

Designed For a
Luxurious and Comfortable
Good Night's sleep

Our Range:

Pillows | Duvets | Quilts | Bed Sheets | Mattress Protectors
Bed Runners | Bed Bases | Head Boards | Roll Away Beds

Platinum Bed International

New Delhi

For Business Enquiry, Contact Arun Pandita: +91 9818324109

Telephone: +91 8586912912, E-Mail: info@platinumbed.com

Website: www.platinumbed.com

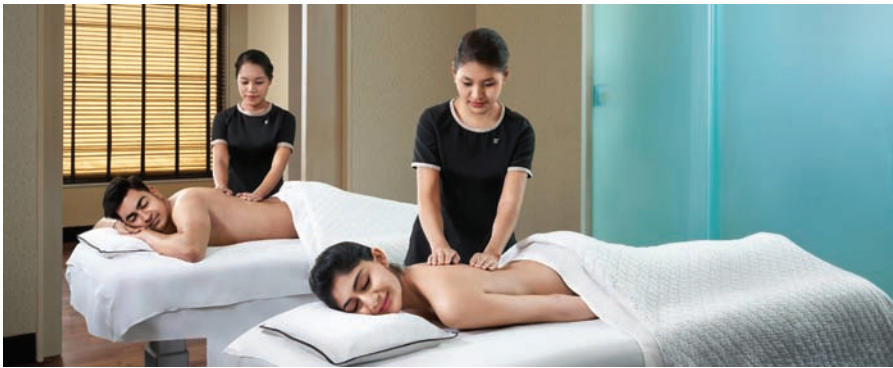

Speaking about refurbishing, he said, “Our spa has been maintained with state-of-the-art furniture and fixtures, the soft soothing colors, lighting, aromas and music of the space only enhances the overall de-stressing relaxation experience.”

Gaurav states, “Post- Covid hotels must ensure that spas maintain social distancing measures, well sanitized treatment rooms, capacity control and well trained professional therapists

“As far as refurbishing is concerned, I would like to stress the fact that wellness facilities should not focus only of spa. Hotels should look at increasing their focus on overall wellness through CrossFit facilities, Aqua aerobics, Yoga Studios, etc .”

Promoting ‘Nature and Nurture’

Wellness tourism, according to a report by Global Wellness Institute, is slated to grow at an annual rate of 7.2 per cent by 2022. This is higher than the annual global growth rate of 6.4 per cent. The lockdown fatigue, remote working and constant fear of infection seem to have spurred demand for wellness packages and stress-relief therapies.

Hotel spas are promoting “Nature and Nurture” programmes in the spas and are also utilizing their open spaces to promote fitness.

Allan disclosed, “Our spa, at the Resort Mumbai, is the perfect combination of nature and nurture. In our relaxing and nurturing treatments, we work on all the aches and pains of the muscles and joints that are caused by daily activities of our sedentary – or even active – lifestyle using natural ingredients that are great on the skin in terms of moisturization, hydration, opening of pores for a complete nourishing experience.

“This lockdown has made us realize the importance of open spaces. Our hotel is extremely privileged to have lush greenery and open spaces. We are looking to work

on wellness packages that will involve yoga, meditation, fitness retreats for holistic wellness experiences for our guests.”

Gaurav states that “Nature and Nurture” is the upcoming trend. “The focus mainly seems to be on therapies incorporating natural elements like local flowers, oil extracts, etc.,” he says and adds, “open spaces in hotels are being used to offer wellness offerings like yoga and group fitness sessions and aqua aerobics.”

Ather declares, “A few trends to promote “Nature and Nurture” which we are following at the Sheraton Grand Chennai Resort & Spa, are:

- Focusing on therapy, mental well-being, inculcating yoga, packages that have a series of sessions to ensure long term health benefits
- Outdoor sessions and promoting “Outdoor Living”
- Using the beach sounds for calmness
- Meditation sessions outside”

He continues, “As far as utilization of outdoor spaces is concerned hotels are using them to offer tranquil environment for complete relaxation and private reflection. Hotels can use these spaces to host wellness programmes like yoga, outdoor fitness or curate local outdoor activities in the hotel. Hotels can also have nature walkways and quaint outdoor settings where guests can unwind amidst lush greenery.”

Neha is of the opinion that “Nature and Nurture” programme can be promoted “by adding wellness food menus to spa facilities, using open spaces for relaxation or maybe even the actual therapy (space & design permitting). One should adopt spa usage as a preventive lifestyle management tool.”

Changes in Wellness Market

There can be little doubt about the fact that post-pandemic the wellness and spa industry will witness an immense change. This is because the experiences at these centres

are all about personal service and human touch. However, despite all the changes, one thing will remain: people will still want to “feel good”. Several hospitality firms as well as online services platforms such as Urban Company have curated packages on stress relief, digital detox and immunity-building meal services to woo customers. It must be realized that wellness and spa are not only about one massage or beauty treatment. It is a continuous treatment and while safety and sanitation have always been essential new measures will have to be taken post-pandemic.

But what should be the changes incorporated and would people be attracted to the spas and wellness centres at resorts?

Neha believes that wellness market will only emerge stronger post COVID. She continues “We at Tattva Spa, Courtyard By Marriott Bengaluru Hebbal, have even designed a lifestyle selection menu – where the therapies focus on day to day issues like hunched back, frozen shoulders, dry eyes, lack of good sleep; some of which have exacerbated during the pandemic, and worsened with the work from home.”

She adds, “Wellness Spas have long been the bedrock of resorts building sustainable businesses across the world. In absence of international leisure travel, the Indian travelers’ wanderlust is taking them to exotic, experience led domestic destinations. Higher proportion of resort guests are seeking out a wellness therapy than before. Having said that, it is the city hotels where wellness has taken more prominence than before. With muted corporate travel, the city hotels are innovating their service offering to reach out to the local catchment. This includes F&B and wellness. With the local community in the hotel’s vicinity trusting the hotel’s sanitization and hygiene standards more than similar facilities at malls, there has been a surge in wellness services consumption at city hotels.”

Ather reveals, “The market has witnessed an increasing focus on fitness, nutrition, and holistic experiences as people now value health and wellness above all else. Travellers are now seeking more healthcare and wellness-related experiences that help restore and boost their overall wellbeing while keeping any kind of infections at bay. The idea of wellness has changed to everyday wellness and is now centered on mindfulness, nutrition, and rest.

“As far as resorts are concerned, it may be said that Resorts dwell amidst rich natural

resources that create serene and holistic experiences and offer the ultimate relaxation for the mind and body. Travellers are looking to travel to more private destinations for safety purposes due to Covid. Moreover, the occupancy rates of resort spas vary from traditional hotel spas as the guests attempting wellness experiences mostly travel keeping in mind the improvement of their health/lifestyle and prefer being amidst nature and tranquil environments.”

Gaurav states, “I believe that wellness market would focus on mindful experiences, which impart a concept of overall wellness and mental recovery.

“Resorts will continue to be the main focus when it comes to wellness centers as the overall theme contributes to a tranquil environment.”

Allan avers, “The demand and need for wellness in everyday lifestyle are surely going to be on the rise. People have realized that the most important thing for them is mental and physical wellbeing. Their inclination will be more towards taking ‘time offs’, ‘me time’, ‘getaways’ as compared to pre Covid-19 times.”

He adds, “Wellness centers will be in demand across the board in hotels as well as high streets. Wellness centers in resorts stand out more than hotels because of the holistic experience. The Resort Mumbai provides the experience of relaxation right from the time you enter the premise. This experience is exclusives to resorts.”

Summing up

The gist of the matter as far as spa and hospitality is concerned can thus be that: it has a bright future.

Ather asserts, “The future of spas and hospitality has been reimagined and they are making a comeback. Following the requisite hygiene measures and maintaining quality standards are at the cornerstone of the hospitality industry. While they are devising new ways to reinvent themselves, we have witnessed an increase in cleanliness measures, smaller and more personalized experiences, enhanced offerings that target specific needs and deep-rooted wellness programmes that cater to the needs of every guest.”

Neha states, “Spa and more so wellness,

is an integral part of the hotel hospitality services offering. Traditionally, the city hotels chose to allocate smaller floor spaces to the Spa due to limited demand for wellness by the corporate traveler staying in the city hotels. As we see demand for wellness services increase in the post-covid world, we believe wellness spaces in city hotels will receive more focus. Quality of wellness spaces & services in the near future will be a key criterion for consumer’s choice of hotel stay.”

Gaurav adds, “The worst is behind us and we expect to see growth owing to the ongoing demand for hospitality & spa services.”

Allan sums up the future of hospitality and spa thus: “The spa culture in India has grown over the last few years. The requirement for good spas in hotels and resorts is now going to be a necessity. People’s realization that their minds and bodies need to relax will lead to an increase in spa usage. Hotels and Resorts will also see an increase in investment to build greater infrastructure and provide state-of-the-art services with this increasing demand.” ■

Discover our range of premium products today!

F & B EQUIPMENT

LIQUOR TROLLIES

BANQUET & CONFERENCE FURNITURE

India’s leading manufacturer in hotel furniture.

SKI
S. K. INTERNATIONAL

E: info@skiglobal.in
W: www.skiglobal.in



Effect of the Budget on Hospitality Industry

Hospitality industry has been severely affected due to the COVID-19 and the restrictions imposed on the tourism sector as well as the hotel industry. India's hospitality and tourism sector is estimated to have suffered three quarters of the economic wipeout which is estimated at Rs. 15 lakh crore. The industry has, thus, been desperately looking for government support to survive and recover in 2021. It's expectations were that the budget would give a boost to the industry. **Ashok Malkani** tries to find whether the budget has offered benefits for the hospitality industry and, if not, whether the industry is expecting some changes in the budget allocations. He also takes a look at the future of the industry.

Hospitality industry, which has been adversely affected due to COVID-19 disruptions and is trying to recover, is, According to ICRA, likely to witness a decline of 65% during the financial year 2020-21. However, the report adds that there might be a recovery in demand in the later part of financial year 2021-2022 as vaccine rollouts gains traction.

The domestic hospitality industry has been one of the worst-hit sectors, severely affected by the COVID-19 pandemic and subsequent lockdowns, which restricted mobility and hotel occupancies in all the major markets, the ICRA report stated. ICRA research observed that pan-India occupancy hit an all-time low of 18-20 per cent in eight months of the financial year 2021, down from

Business

64-65 per cent in the previous year.

According to an in-depth survey conducted by Jones Lang LaSalle (JLL) with key hotel operators, about 53% of the total leading hotel operators shut down more than 80% of their inventory during the nation-wide lockdown period.

A study by Deloitte Canada yielded conclusions that potentially translate to every market. Facing a crisis, most customers intend to reduce spending on travelling and restaurants. It is believed that economy hotels would recover faster since there would be more demand, less maintenance and fewer labour costs.

Suniil Bhatia, Director, Sales & Marketing, Mirador Hotel, Mumbai declares, "The hotel industry particularly in the metros has been severely impacted by Covid19, having seen a major drop in occupancies ever since the lockdowns began in April'20. This is primarily due to a halt in corporate and inbound travel. Even corporate events have not been happening with only the weddings segment opening up a bit since the last 2 quarters or so. Some domestic/Indian corporates have taken some measures in re-starting their events and travel in a modest way. Multinationals are yet to restart their travel and events as they are basically taking decisions in tandem with their out of India regional and global offices which have also been impacted."

Sherry Bhatia, President, Hotel & Restaurant Association of Western India (HRAWI), adds, "Tourism and Hospitality account for close to 7 per cent of India's GDP and support around 90 million jobs. The unprecedented COVID-19 crisis has caused roughly 50 per cent job loss for people employed in the sector. The Hospitality industry has no foreign exchange earnings and revenues are less than 10 per cent of pre-pandemic levels. The sector required working capital which has been difficult to obtain. The lockdown of

close to seven months has caused revenue loss and debts are mounting. Under such a scenario, the sector is in desperate need for loan restructuring. The industry faces a bleak business scenario for at least the next one year and is in need for interest waiver and if not, then the banks should be directed to charge interest on loans at fixed deposit rates plus 2 per cent capped at 9 per cent, at least for a year. From here, achieving even 25 per cent of pre-pandemic revenues in the near future seems very unlikely. The Hospitality sector is facing an existential crisis."

Gurbaxish Singh Kohli, Vice President of Federation of Hotel & Restaurant Associations of India (FHRAI), claims, "The Hospitality industry has lost almost all of its revenues after the lockdown came into effect. There was no support from the Government then and there is none even now. We are facing shortage of manpower, expense and debts are mounting, and sales are struggling. Hospitality establishments are finding it increasingly difficult to sustain. The industry's most critical problem today is that it is finding it difficult to mobilize loans and financial institutions have marked the industry in negative list. A working capital support from the Government will help the hotels and restaurants that are struggling due to negative cash flows, to restart and sustain their operations. Besides this, curbs on travels remain and migrated staff is not being able to return for work which also affects the working of an organization."

Budget 2021 to aid hospitality?

Hotel industry, which is considered to be the sunrise sector, contributed about 7 per cent to the country's GDP and was on a growth path, before the COVID-19 pandemic struck and robbed the industry of its sheen.

Since the hospitality industry, besides being a major contributor to the country's GDP, is one of the largest employment generators in

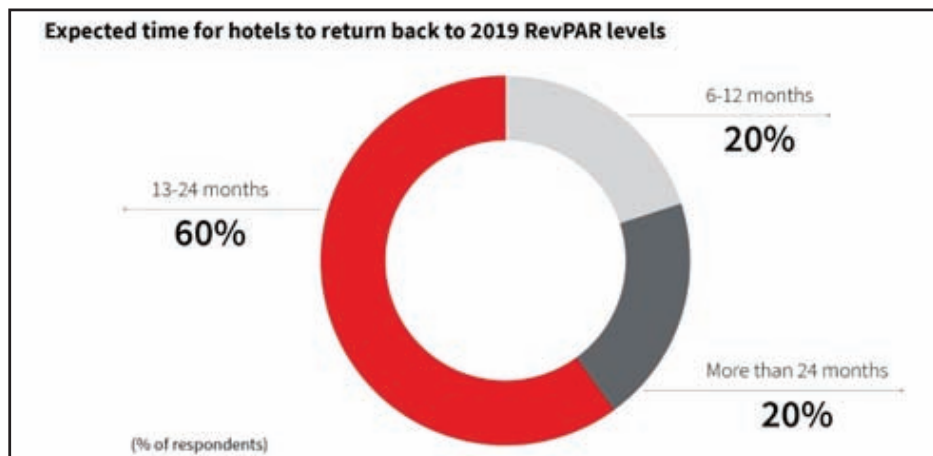

FURNITURE FOR EVERY SPACE



providing customised solutions for our products



An ISO 9001:2008, OHSAS 18001:2007 & ISO 14001. 2004 certified company

Showroom Address 1:

9/50 1st Floor, Industrial Area, Kirti Nagar, New Delhi

The Courtyard

Showroom Address 2:

B 118 A, Mansarovar Garden, Delhi, (Opp Kirti Nagar Police Station)

Showroom Address 3:

2/69, Main Road, Kirti Nagar, Near SBI, New Delhi-110015

Contact No. : 9212367788, 9212023337

Email: monika@metropluslifestyle.com,

sheepa@metropluslifestyle.com

Website: www.outdoorfurnitureindia.in,

www.restaurantfurnitureindia.com



Sherry Bhatia



Sarbendra Sarkar



Suniil Bhatia



Gurbaxish Singh Kohli

the country, it would be essential for the government to come to its rescue and it was looking expectantly at the Finance Minister, Nirmala Sitharaman, to come up with a Budget 2021 that would rescue the industry from its present predicament. So, has the budget fulfilled the industry's expectations?

According to Gurbaxish Singh, "The Union Budget 2021 has disappointed the Hospitality industry."

He adds, "With zero foreign exchange earnings and less than 15 per cent of pre-pandemic revenues, the sector is facing an existential crisis. The Hospitality industry has been bleeding, and the FHRAI has brought it to Government's notice through several representations time and again. Our pre-Budget memorandum to the Finance Minister included some priority reforms to stabilize the industry such as review of the Kamath Committee recommendations, classifying Hospitality under the RBI Infrastructure lending norm criteria, Industry status to hotels, restaurants and resorts across the country, to include Hospitality and Tourism in the concurrent list, MAT waiver for a period of three years, IGST billing to hotels for corporate and MICE bookings. The Union Budget completely ignored hospitality and tourism. The industry is disheartened and feels demotivated in its darkest hour."

Sherry Bhatia declares, "The Union Budget 2021 has ignored the Hospitality industry once again. The Maharashtra Government recently announced Industry status to the sector and we were hoping for the Centre to also announce the same. This alone could've made a world of difference to our industry specially to tide over these trying times. Instead, the Centre has slashed the Budget allocation to the Ministry of Tourism by 19 per cent. This has come as a shock to the Tourism industry which is right now required to spend more to encourage as much domestic tourism as possible in the absence of international travellers."

Suniil Bhatia disclosed, "The Hotel Industry was expecting the 2021 Budget to be friendlier towards them. It however does not seem to have been that way. We are disappointed at the lack of direct support to help the industry. Though there is a boost given to the Infrastructure Sector, it may take some time for its positive effects to be seen towards the Hotel and Tourism Industry. More relief was expected for the Travel and Tourism Sector as a whole. Even now The Hotel Industry awaits the Infrastructure

and Industry status as do Restaurants and Resorts classifying hospitality under RBI's infrastructure lending norms criteria for access to long term funds besides granting a MAT (Minimum Alternate Tax) waiver to the industry for a period of three years beginning April 2021 to March 2024."

Sarbendra Sarkar, Founder & MD, Cygnett Hotels and Resorts, however, believe that the budget will have a positive effect. He states, "While there is nothing specific on the tourism and hospitality sector in the budget, I feel broader focus on the budget on increasing consumption and infrastructure spend by the government will have a positive impact on the hospitality sector. The government has done the right thing by not introducing any new tax or COVID cess as some had anticipated. We also believe that the amount allocated for COVID vaccination is a positive for our sector as more people get vaccinated it will encourage people to travel."

Mustakeen Sheikh, Co-Founder Realta Ventures and spokesperson for London Bubble Co., too views the budget favourably. He states, "Firstly, we'd want to laud the Government for presenting a Budget that is nothing short of an energizer for both businesses and taxpayers. The budget shows immediate relief measures for businesses across sectors with a foresight to reset the economy."

He adds, "Furthermore, incentivization of digital mode of payments will play a crucial role in shaping and strengthening the infrastructural and transactional solutions for B2C entities. This will enable businesses to adopt a cashless format, streamlining internal procedures and increasing scope to expand and flourish. Also, with no tax burden imposed on the end consumer, we are glad that this will leave more discretionary spends among them allowing resurgence of various consumer led sectors. Additionally, investments on COVID vaccinations will help bring back confidence among consumers and provide an impetus to the F&B industry."

Interconnection between Tourism & Hospitality

Hospitality and travel and tourism is believed to go hand-in-hand and tourists form the backbone of hospitality industry. If the budget is favourably inclined to the travel and tourism industry, it would, indirectly help the hotel industry. Tourism is the activity where the tourists travelling to different destinations want to experience recreational

and leisure activities and most of the time avail of accommodation, food and beverage. The hospitality industry is the supplier of the services for tourism. Thus a boost in tourism would definitely help the hospitality industry. So has the budget helped in promoting the tourism sector?

Sunil avers, "Since only the domestic leisure segment has picked up since the lockdowns were lifted and domestic airlines, hotels and restaurants were allowed to restart their operations, there is no great impact of the 2021 budget on the on the travel and tourism industry and, subsequently, on hotel industry. The Rs. 35,400 crore for Covid-19 vaccination in 2021-22 may however add some confidence in travellers to restart their business and leisure travel. The government's focus on extending and improving transport (road, railway, metro) infrastructure to be completed under national infrastructure pipeline will enhance domestic tourism and hospitality industries. An overall focus on technology with interventions like incentivizing and promoting digital payments will fast track India's transition into a digitally enabled economy. Privatization of airlines, allocation of 1.10 lakh crore for railways and a boost to infrastructure development such

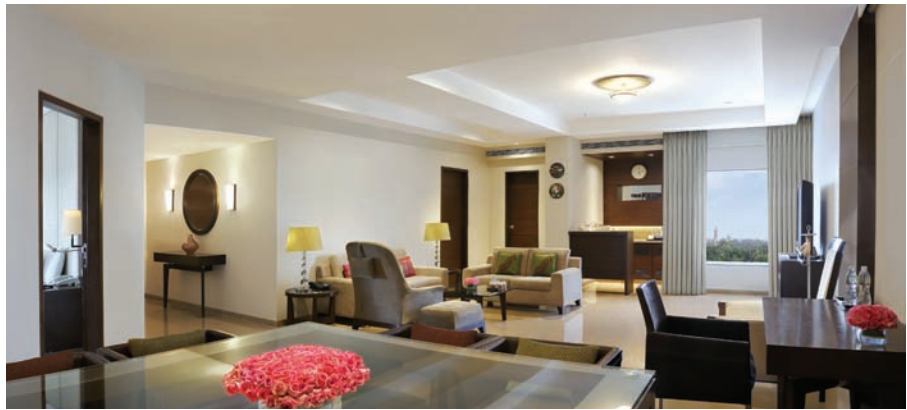

as development of new highway projects are positives in the budget 2021, for the hotel industry."

Sherry asserts that the budget does not, in any way, help the travel and tourism sector. He stressed the fact that there was a reduction of 19% announced in the budget for the Ministry of Tourism. "There was nothing in the Budget to help the travel industry and, subsequently, the hospitality sector," he claimed.

He added "Our apex Association FHRAI has now written to the Prime Minister to seek a meeting with him to personally apprise him of the industry's concerns."

Changes in the Budget?

Since the general consensus in the hospitality industry is that the budget is not hospitality industry friendly it is likely that the Finance Minister may make some changes in the budget, particularly since the tourism and hospitality industry is considered as one the key drivers of growth among the services sector in India. Even the Prime Minister, in his Independence Day speech from the Red Fort showed his awareness of the importance of travel and tourism sector when he urged the people to visit 15 domestic tourist destinations in India by 2022 to promote tourism and, in turn the hospitality industry.







The Best Place
To Find The Best
PRODUCT.





GLOBAL LINEN COMPANY
59/A,B & C, AASHIRWAD INDUSTRIAL SOCIETY - 1,
NEAR KOMAL CIRCLE,
BAMROLI ROAD,
SURAT.-394210 (GUJARAT)INDIA.

+91-90818 49490 / +91-7405051489
info@thefabura.com
www.thefabura.com
www.globallinencompany.in

BRANCH OFFICE:
704, BASEMENT,
NEAR DELHI METRO APT.,
SECTOR-46,
GURUGRAM-122003(HARYANA)INDIA.

Manufacturer, Supplier & Exporter Of Hospitality Fabrics & Made-ups.

Yet the budget does not, according to the hospitality industry, have much cheer for the hotels and F&B sector. Will the Finance Minister make some changes, and if so, what would be the changes the industry would like?

Gurbaxish Singh is surprised that the sector could not find even a mention in the Finance Minister’s Budget. He stressed, “Hospitality and Tourism roughly account for 7 per cent of India’s GDP and employ nearly 9 per cent of India’s working population and yet, it failed to find space in the Union Budget. As mentioned earlier, there were several things that the Budget could have addressed and accommodated for the Hospitality industry but it completely ignored the sector. We wish our Govt. would study what other countries have done to ensure tourism, the worst-hit sector, is kept alive. The Hospitality and Tourism industry was looking forward to some relief measures to lift this most severely affected industry by COVID-19. Instead, it has yet again completely and fully chosen to ignore us.”

He asserted that changes should be made and said, “Our recommendations are:

- MAT waiver be given to the industry for a period of three years beginning April 2021 to March 2024
- Treat payments received from international tourists as Foreign Exchange for the purpose of EPCG scheme and that the time to perform export obligation under the scheme be extended by 5 years
- Being a highly capital intensive industry, extend investment linked benefits from section 35 AD to on-going cap-ex of hotels and resorts to promote high quality brownfield cap-ex and capacity expansion
- A review of the Kamath Committee recommendations for loan restructuring and lending to Hospitality establishments
- Industry and infrastructure status to hotels, resorts and restaurants in the country
- Raise threshold limit of hotel room tariff for charging GST, and
- Allow IGST billing to hotels for corporate and MICE bookings, among other things to rescue the Hospitality industry from the current downward spiral.

Sunil stated that the expected changes had not been made. He declared “The Finance Ministry seems to have taken a holistic approach by trying to speed up the vaccinations and improve infrastructure to boost consumer confidence and mobility. They should still reconsider the points put forth by the industry before the Ministry

Hotel development and openings - Deferring of new openings.

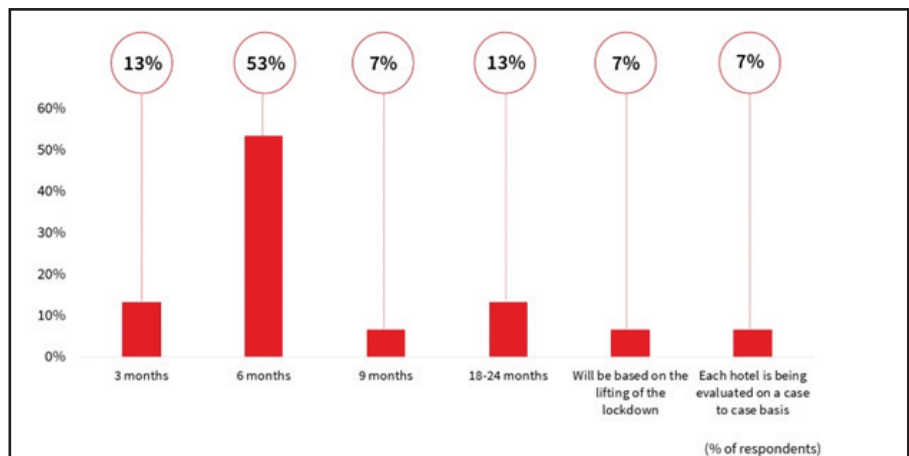

earlier.”

Sherry disclosed, “In our pre-Budget memorandum to the Finance Minister, we had requested for some priority reforms for the sector. We had requested for a review of the Kamath Committee’s recommendations for the Hospitality industry. The present conditions laid out in the recommendations are even more discouraging for our industry than they were before. We had pleaded to the Ministry for classifying Hospitality under the RBI Infrastructure lending norm criteria and Industry status to hotels, restaurants and resorts across the country. Also we had asked that the banks be directed to restructure accounts that were standard assets as on 1st March 2020 and banks should not have discretionary power to reject the proposal on any grounds.”

Future of the industry

The year 2020 has been a year which has seen changes that were not even remotely thought of. It reminds one of Vladimir Ilyich Lenin’s quotes: “There are decades where nothing happens; and there are weeks when

decades happen.” Over the last year human behavior has changed – right from wearing masks to guests booking hotel rooms so that they could work peacefully. A sector that traditionally offered a high-touch experience moved to using contactless technology and observing social distancing.

With the adverse effect on travel and tourism industry, due to the pandemic, the hotel industry continues to witness a decrease in room occupancy. The F&B sector has also been unfavourably affected.

According to a survey by JLL there are different opinions by hoteliers about when things would return to the pre-pandemic days.

As far as deferring development of hotels and deferring of new openings are concerned opinions differ with about 53% believing that it will take about 6 months after things have normalized.

So, what would be the future of hospitality industry?

Gurbaxish Singh declares, “Hotels occupancies are in single digits and recovery is not foreseeable in the near future. Revenue loss is easily somewhere in the range of 70 to 85 per cent to the corresponding period of the previous years. The total value at risk to the entire economy is at approximately 10 lakhs crores and more than 50 per cent job losses within the industry. As per a recent report, the full year occupancy of the hotels in the country in the year 2020 was at 34.5 per cent and occupancy during the pandemic period was at 27.8 per cent. Several key markets reported pandemic period Revenue per Available Room (RevPAR in Rupees) in the 100s with Ahmedabad at the bottom with RevPAR at Rs.672. If the poor business conditions persist, it is anticipated that many businesses won’t be able to service



Mustakeen Sheikh

their financial obligations and eventually slip into the most distressed category.”

Sunil, however, is optimistic. He states, “Though the oil & gas exploration, commercial real estate, automobile, life and health insurance industries etc. have been at the top, till 2018, the travel & tourism sector accounted for nearly 10.2% of global GDP.

“On a personal note, the Sector has a very bright future as there is so much pent up demand in the market now that any and everyone just wants to go out and live life to the fullest. With the world population also going up by the decades, it’s like a volcano ready to erupt and we might as well become the no 1 Industry in the world as we are interlinked to the success of all the other Industries who need to keep having budgets to keep up their game.

“Though zoom calls have saved corporations much in terms of space rentals and travel, R&R, incentives and event spends for the while, it may well be fashionable again to ‘live the life’ once they start making profits again. The pandemic has just been a reset for us to become wiser and re-launch ourselves in our better forms and futures in the next 2 to 3 years time. Countries

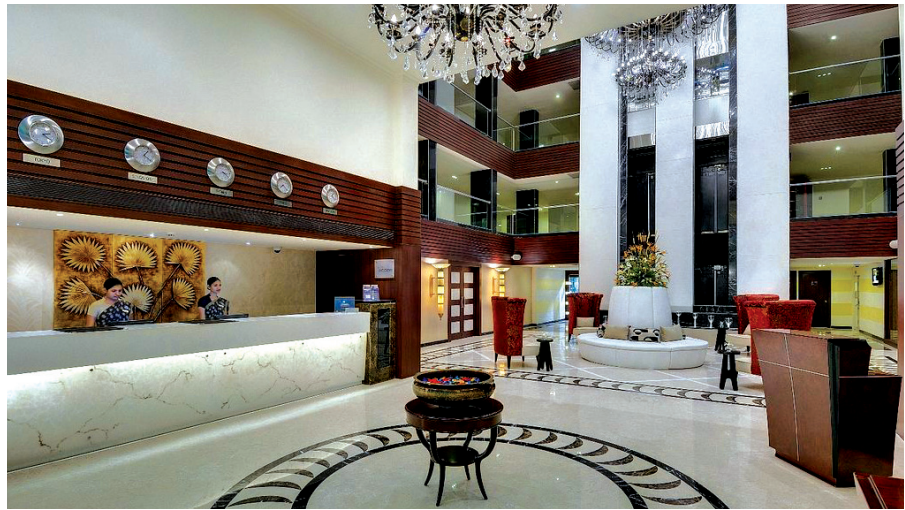

will do whatever is possible to restart their economies and this will create a huge pull once again for travellers to explore, engage and enjoy life once again. 2021 till 2030 (this decade so as to say) are years worth watching for. Employment still remains a concern as automation and digitization of many functions has already taken place. It would hopefully be taken care of as the industry further matures and expands in Tier 2 and 3 Cities and penetrate further

to newer areas which have business and tourism potential.

“On a utopian note, would like to see the travel and tourism sector become No 1 in the world at its peak as it exhibits culture, art, food, and so many facets of life that life itself would be incomplete without them. The wanderlust which humans have to explore the unexplored and have newer experiences in their lifetimes would indeed be worth it and possible only via our industry.” ■

Stackable Aluminum, Banquet & Conference Chairs				Actionback Chairs			
WA21 with & without Arms	WA27	WA29SP					
Stackable Steel Tubular Powder Coated Chairs				Banquet Tables			
WS21	WS25	WS26					
Multi-utility Conference Tables				Glass Top Tables		Stages	
				Contact No.: +91 9850324262 / +91 8888871869 Email: sales@stackwell.in / banquetfurniture@gmail.com / pethevs@hotmail.com Website: www.stackwell.in Made in Pune, India			

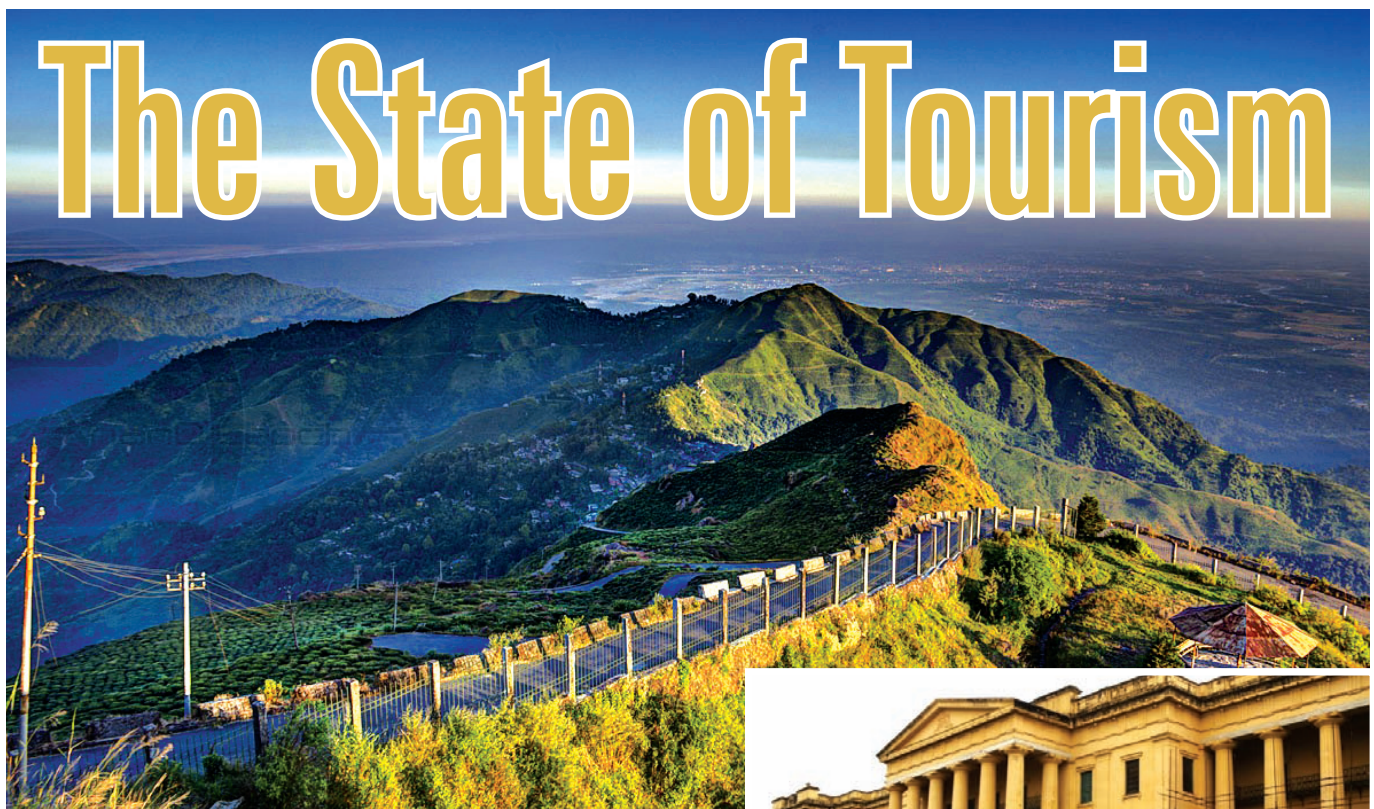

By Jhuma Biswas

West Bengal is a state of awesome and diverse tourist attractions. From quaint sea side towns and sea resort villages where one can marvel the Bay of Bengal in its turbulent glory to scenic hill stations from where one can enjoy the majestic Himalayas; from jungles teeming with fascinating wildlife to stately palaces resonating with centuries of heritage... from taking part in massive religious fairs where one can lose oneself to one's outward celebration to visiting plethora of temples and other places of worship where one can find oneself in one's inner introspection... West Bengal is a state of immense tourism potential which is still largely untapped by India's hospitality industry at large.

Now as the post-lockdown economy has slowly opened its shackles and the tourism has begun, both our domestic and inbound tourists can explore the fabulous tourism bounty of West Bengal; a state whose reputation as a tourist destination often gets overshadowed before the popular tourism appeal of Rajasthan, Goa and Kerala.

For wildlife enthusiasts and nature lovers, Dooars in West Bengal can be a welcome destination. The writer finds it alarming that even a great many educated people outside Bengal (who are not related to the tourism industry) have not even heard of this

natural paradise enveloped in greenery. For that I think West Bengal Tourism should shoulder the blame for not popularising enough the tourism bounties of the state, which in turn could have attracted more investment from the hospitality sector to tourism destinations in West Bengal.

Where Nature has its Doors Open

Located in the foothills of the eastern Himalayas, close to Bhutan, Dooars is enriched with great natural beauty. The name Dooars is derived from 'door' as the region can be construed as the gateway to Bhutan from India. Sankosh river demarcates the Dooars region into Eastern and Western Dooars. The Dooars region spreads from north Bengal to Assam. The Western Dooars is also known as Bengal Dooars, and Eastern Dooars is also known as Assam Dooars.

Rolling hill slopes, lush green tea gardens segmented by pristine white river streams, vast meadows, forests teeming with wildlife and quaint tribal villages together make for a wonderful memorable travel experience in Dooars. Several streams and rivers flow through these fertile plains from the mountains of Bhutan. The major river in the region of Dooars which fall in West Bengal is



the Teesta though there other water bodies flowing through the region like the Murti, Torsa, Jaldhaka, Sankosh, Karatoya, Raidak, Dyna, Kaljani among others.

Tea, timber and tourism are the main industries of Dooars region. And one of the chief tourism attractions of Dooars is the visit to its wildlife sanctuaries and national parks.

The part of the Dooars which lie in the state of West Bengal has several wildlife sanctuaries and national parks which include Jaldapara Wildlife Sanctuary, Gorumara National Park, Chapramari Wildlife Sanctuary, Chilapata Forests, Buxa Tiger Reserve, Singalila National Park, Neora Valley National Park, and the Mahananda Wildlife Sanctuary.

Jaldapara Wildlife Sanctuary happens to be the habitat of the rare one-horned rhinoceros. Of course, bison, spotted deer, sambar, hog deer, huge tuskers, and rare variety of feathered species can also be spotted amidst its greens. Elephant riding through the sanctuary and catching the wildlife with binoculars or shooting them with camera could be a wild experience of

a lifetime at this sanctuary.

Gorumara National Park should also be a must visit attraction for wildlife and nature lovers visiting Dooars. The national park full of sal and bamboo trees, which is located on the floodplains of Murti and Jaldhaka rivers, offers an awesome variety of flora and fauna, whose chief attraction is of course Asiatic one-horned rhino. The jungle safari through the park can not only help one get majestic views of Asiatic one-horned rhino, but one can also sight elephants, Indian bison, peacock, herds of deer, sloth bear, wild boar, barking deer, endangered pygmy hog, giant squirrels among others in this national park.

Hiking to a charming village named Jayanti, which is a small forest village located along with Jayanti river and within Buxa Tiger Reserve, can also be a nature lover's treat when visiting the Dooars. The breathtaking beautiful landscape, dotted with wild fountains, make the hiking journey to this village worthwhile.

Forests, Cruises and Roars

For tourists to West Bengal, especially those who are wildlife lovers, Sunderbans can be a major attraction. Just 110 km from Kolkata, Sunderbans, a UNESCO World Heritage Site, is the world's largest tidal delta, formed by the confluence of the Ganga, the Brahmaputra and Meghna rivers in the Bay of Bengal. Sunderbans has the largest mangrove eco-system of the world. The mangrove forests of Sunderbans are spread across 10,000 sq. km and passes through West Bengal and Bangladesh. Sundri is the most abundant tree species found here from which the region derives its name. The forests of Sunderbans are interspersed with villages with human habitations.

In Sunderbans, one can find a plethora of birds, mammals, and reptiles, but the forests have attracted its global fame because of Royal Bengal Tiger. The best way to explore Sunderbans is through launches or boats which move through its vast waterways network, comprising hundreds of creeks and tributaries.

The vast greenery of Sunderbans is punctuated with wild roars. The thick mangrove forest of Sunderbans is home to close to 250 tigers. The region also has 260 bird species. Besides that chital deer, rhesus monkey, Ridley Sea Turtle, estuarine crocodile, barking deer, endangered river terrapin, hermit crabs and many other land and aqua species can be spotted during the tourists' Sunderbans itinerary.



Besides enjoying the rich variety of wildlife and cruising through the intricate waterways network, tourists visiting Sunderbans region should also explore several tourist worthy destinations, which include Henry's Island, Bakkhali, Haliday Island Wildlife Sanctuary among many others.

Feel the Sea in You

For those who want to have a quiet vacation by the sea, the offbeat destination of Mandarmani in West Bengal can be a fascinating option. During the recent years, the destination has gained prominence in West Bengal's tourism map.

Located 180 km from Kolkata airport, this seaside village lies in East Midnapore district of West Bengal. It is located at the northern end of the Bay of Bengal. The village by the sea doesn't have rail service or airport, and one needs to travel by the road to reach Mandarmani. The nearest airport is in Kolkata, and Contai and Digha are the nearby railway stations to Mandarmani.

Those tourists who are looking for a busy itinerary; eager to hop from one tourist spot to the next at frantic space, are likely to get disappointed with Mandarmani. But those who are looking to have a wonderful retreat far from the madding crowd; those who are in passionate love with nature; those who travel not merely to see places but to get memorable experiences to cherish would surely love Mandarmani.

It is widely believed that Mandarmani beach is the longest motorable beach in India. A ride on the beach can give great enjoyment to the tourists. The red crabs crawling on the 13 km long beach would heighten the enjoyment of the beach with its grey-blue waters crashing on the shore ...

Watching the crimson sunset amidst the roaring waves at Mandarmani can give an ethereal feel. The fact that the beach is still sparsely crowded as compared to Digha and Puri beaches nearby helps one to feel the

vastness of nature more strongly. Solitude here is also complemented with fun. Water sports at Mandarmani can also be enjoyed, which include jet skiing, parasailing, banana boat rides among others.

The place has already gained popularity among weekend tourists in West Bengal, but it deserves national and even international popularity. In the national tourism map, Mandarmani is still an obscure destination, where the ambience of tranquility is often only punctuated by the roar of the sea.

The Charming Retreat

West Bengal also has many wonderful hill stations besides the crowded Darjeeling, which not many common domestic and inbound tourists are aware of. They need to be projected and popularised more vigorously by the West Bengal government and also by our hospitality industry at large.

One of them is the quiet Kurseong, situated in the Darjeeling district of West Bengal. Dotted with pine forests and visually appealing schools embodying quality education and Victorian architecture; often enveloped in cloud and mist and always nestled in hills with toy trains chugging through its solitude, Kurseong can be a wonderful retreat for a short vacation... far from the madding crowd.

Kurseong is 47km away from Siliguri (one of the important cities of West Bengal) and just 30 km from Darjeeling. Between March end to May and from August to October are the best time to visit this quaint hill station located at 4864 ft. above sea level. In the colonial era, Kurseong was a preferred destination for sanatoriums where the sick would be ideally recuperated.

Trekking through the hills can be a nice way for tourists to explore this picturesque town and its surroundings which can also give them views of the mighty Kanchenjunga, Nathu-la Pass, and Jelep-la Pass on a sunny morning. One can also explore white water



rafting on Teesta river while in Kurseong. Makaibari tea estate, one of the oldest tea estates near Darjeeling and Kurseong, is also worth a visit where one can get fascinating glimpses of tea garden and its workings.

Dow Hill, one kilometer climb away from Kurseong, is a forested area which nature lovers would love to visit. Here you can visit the Dow Hill Park, which was earlier known as Deer Park as you could see lots of deer here, and also the forest museum maintained by the forest department. Just near the Dow Hill Park is a water reservoir, which affords a scenic view of the plains.

Also do not forget to have a panoramic view of the tall green sombre mountains, charming hamlets and verdant tea gardens from Eagle's Crag Viewpoint, perched on a cliff, before leaving this enchanting hill station.

Devotion and Congregation

West Bengal is also a state of colourful fairs and festivities. It has a number of festivities besides the world renowned Durga Puja, which can attract many connoisseurs of cultural tourism to the state. One of the most significant fairs in the state is the Gangasagar Mela.

Gangasagar or Sagar Island is a large island on the Ganges delta, spread across 224.3 sq.km, lying on the continental shelf of the Bay of Bengal. It is only 100 km south of Kolkata. A car ride of three hours from Kolkata along the Diamond Harbour Road can take you to Harwood Point, from where a ferry service would enable you to reach this tranquil island. The Ganges and the Bay of Bengal are the vast water bodies which surround this island.

Every year, on the day of *Makar Sankranti* (14th January), lakhs of pilgrims from India and abroad gather in this island to take a holy dip at the confluence of river Ganges and the Bay of Bengal and to offer prayers (*puja*) in the Kapil Muni Temple or Ashram, which is located on Gangasagar island itself. The temple attracts great reverence among devotees and is associated

with many legendary tales. The prayer at the temple is followed by the dip. On this occasion a huge fair also takes place in Gangasagar or Sagar Island. Naga *sadhus* are one of the chief attractions of the *Gangasagar Mela*, who perform various rituals and various forms of yoga.

Both the annual pilgrimage and fair take place on the southern tip of the island. It is interesting to note that the Gangasagar pilgrimage and the fair account for the second largest congregation of mankind in the world after the Kumbha Mela. According to a news report, on 14th January 2018, around 18-20 million people had visited Gangasagar, as compared to 1.5 million in 2017.

Gangasagar Mela took place in 2021 too, of course amidst strict Covid-19 protocols introduced by the administration. Gangasagar Mela for this year was allowed by the Calcutta High Court. Pilgrims were permitted to go for a dip in a staggered manner for maintaining social distancing.

However, Gangasagar island is not only for religious tourism. With its unspoilt beach with dazzling silver colour sand on the estuary of the Ganges, with its views of the calm vast sea, the island can also be projected as an apt destination for nature lovers among domestic and inbound tourists. The lighthouse at Gangasagar offers captivating views of the sunrise and sunset from and on the waters, respectively.

Especially in these Covid inflicted times, where huge congregations are justifiably discouraged, it is great to position Gangasagar as a destination for exploring the beauty and vastness of nature too.

Where History Resides

For those in love with history and heritage, Murshidabad in West Bengal is an ideal tourist destination to explore upon. Situated on the banks of the Bhagirathi river, Murshidabad was the last capital city of independent Bengal before the advent of British rule in India, in the mid 18th century. One can meet fascinating history here, there

and everywhere in this town.

One of the chief attractions of Murshidabad is the Hazarduari Palace. This erstwhile majestic palace of 1000 doors, 114 rooms and eight galleries had been turned into a museum. Here one can marvel at the wonderful collection of armours, paintings, portraits of Nawabs, ivory works and many other invaluable art works. Nasipur Palace, Khosh Bagh, Jafarganj Cemetery, and Katra Masjid are among other notable places of tourist interest in this historical town.

So we can see that the state of West Bengal is a treasure-trove of varied tourist attractions, which need to be projected more aggressively as well as creatively by the government of West Bengal and India's hospitality industry in a concerted manner. Along with that the tourism infrastructure in the state also needs to be further improved. Then only the state's awesome tourism potential can be fully or near fully tapped.

According to the Ministry of Tourism's figures, the number of domestic tourist visits to West Bengal during 2018 was 85657365 whereas the number of foreign tourist visits to West Bengal during 2018 was only 1617105. During 2017, according to the Ministry of Tourism figures, the number of domestic tourist visits to West Bengal was 79630345, whereas the number of foreign tourist visits to West Bengal during the same year was 1574915.

In 2019, the number of domestic tourist visits in West Bengal rose to 92366025 (provisional figures), whereas the number of foreign tourist visits to the state rose to 1656145 (provisional figures). Though the tourism growth in West Bengal seems encouraging, but the statistics still do not adequately reflect the huge tourism potential of West Bengal. Still lot needs to be done as far as promoting tourism in West Bengal goes.

Note: Some of the tourism attractions, initiatives and exercises described here may not be open/carried out at present due to the affect of the Covid pandemic.

Perfection Personified



PUSHKAL
TEXTILES



B-15, L.G.F., DDA Shopping Complex,
New Rajender Nagar, New Delhi 110060
Tel : +91 9811549008, 9811169567
Email : pushkaltex@gmail.com
Website : www.pushkaltextiles.com

Delivering Perfection Since 1999

Bed Sheets, Pillows, Pillow Covers, Duvets, Duvet Covers,
Cushions, Mattress Protectors, Bath Robes, Bath Towels,
Hand Towels, Face Towels, Bath Mats, Pool Towels and more

Some of our esteemed clients:



Nostalgic Flavours of Soulful Comfort Food

By Sharmila Chand

Gourmet food and fancy chef's table has its own charm and place but what draws us anytime at any place is warm, simple, familiar food. Food which is laden with nostalgic memories, familiar environs, distinct flavours, lovable presentation and positive vibes. Ask any chef from any part of the world, holding several Awards and Badges, and he or she will reveal, nothing beats 'Comfort Food' at the end of the day. It is endearingly refreshing and de-stressing for all.

What is Comfort Food?

"Food that brings happiness, food which has some good memory associated with it is, food that one has at the end of a long, hectic day, food which instantly transports me home is what comfort food is all about for me," says Altamsh Patel, Executive Chef, Oakwood Premier Prestige Bangalore.

Likewise for Sumit Sinha, Director of Food & Beverage, Crowne Plaza Today New Delhi Okhla, "Any dish that evokes a sense of nostalgia and escapism to a safe space could be your soul food or comfort food. It is simple, comforting and soul nourishing that has a capacity to uplift one's mood instantly. It can act as a relaxed therapy as well as coping mechanism. Someone might find solace in the humble 'Dal Khichdi' while another can find that comfort with instant noodles. We witness maximum footfall of the guests during the annual Dilli 6 food festival at Edesia. Our patrons love the 'authentic' Chaat, Papri, Dahi Bhalla, Golguppa & Daulat Ki Chaat experiences at our live counters as it instantly connects them to their fond street side Chaat memories".

"Food that provides consolation or a feeling of well-being and can be associated with childhood or home cooking is comfort food," according to Chef Utkarsh Bhalla,



"Food for the body is not enough, we must have food for soul as well and that is comfort food"

Sumit Sinha, Director of Food & Beverage, Crowne Plaza Today New Delhi Okhla

Brand Chef, Sly Granny. He adds, "It makes a person feel better and positive. Sometimes eating some particular kind of food gives a distinctive pleasure or temporary sense of emotional elevation and relaxation. There's always a psychological comfort. Oftentimes, these foods remind us of fond memories or occasions or connected to family, friends & relatives."

Philosophy of Comfort Food

Altamsh Patel, Executive Chef, Oakwood Premier Prestige Bangalore

In most cases, comfort food is something you grow up eating and has a strong connection to your childhood. Over the years the pace of life has changed quite a bit with most of us having very hectic schedules, skipping meals etc. In many cases, we also live away from home and our families and that's where the whole concept of comfort food comes in. It is something which connects us to our roots, giving us the comfort of home and playing a very important role in all our lives.

Sumit Sinha, Director of Food & Beverage, Crowne Plaza Today New Delhi Okhla

A dish becomes your comfort food primarily because of the connection you feel with it. This could be due to multiple reasons such as: You have been eating that dish since childhood and your palate relishes every morsel of it. Someone close to you used to cook it for you which instantly transport you to the same time period. It distracts your mind from discomfort if you are stressed or upset. It is quick and easy to make and gives you respite from instant hunger. The dish is light to your digestive system and its simple flavour heals your taste buds.

Chef Utkarsh Bhalla, Brand Chef, Sly Granny



“Comfort food is that which brings a smile to your face, warms up your soul and invariably has a story behind it”

Altamsh Patel, Executive Chef, Oakwood Premier Prestige Bangalore

According to me Comfort food is food that provides a nostalgic or sentimental value to someone. Something that is enjoyable to eat and makes you feel happier. Perhaps preparing the same meal over and over again with expected results provides you comfort.

Despite any outside stressors in your life there are certain aspects of your life that you can control – and one of those is certainly your meal choices. There is something about a special meal or ritual that makes us feel “full” and recharged. My focus has always been on comfort food, because at the end of a long work day, you want something comforting.



Is Comfort Food Trendy?

Altamsh Patel, Executive Chef, Oakwood Premier Prestige Bangalore

Yes, comfort food will always be trendy. It is a part of who we are and in most cases are dishes which have all the goodness of nature with immunity boosting properties and nutrients. Recently we noticed that even fine dine restaurants are introducing comfort food in their menu.

Sumit Sinha, Director of Food & Beverage, Crowne Plaza Today New Delhi Okhla

The definition of comfort food can be different for different generations as well. It includes but may not be restricted to ‘mom made’ home cooked food or regional delicacies. A new term has emerged in the hospitality industry’s dictionary- known as ‘Modern Comfort Food’. Millennials love to gorge on classic Pizzas, Ramen, Tacos, Sundaes, Burgers, Mac & Cheese, Hot Chocolate and that could be their comfort food as well.

Chef Utkarsh Bhalla, Brand Chef, Sly Granny

Although there’s certainly been a push toward health and wellness in recent times, consumers are still craving nostalgic, indulgent foods and flavours. I think with the pandemic and lockdown people have gone back to enjoying the comfort food and also experimenting with the food, trying different things at home which gave them pleasure and relieved them from the stress and negativity. The demand for some comfort foods, including pizzas, gourmet burgers, hot dogs and other snacks, have skyrocketed during the pandemic.

Consumers have been gravitating toward a “treat yourself” mentality, where foods with super-indulgent flavours and ingredients are in demand. Snacking is meant to be a treat, so they’re looking for foods and flavours that really feel like that.

Taking advantage of seasonal trends is a great way of adding an extra layer of nostalgia. Flavours such as apple pie, pumpkin roll and sugar cookie allow consumers to both indulge and celebrate the season. From dairy-based beverages to cream cheese dips, these flavours work well in a variety of dairy applications. These are the foods that we grew up with, foods that make us feel nostalgic. They are foods that feel inherently good because they remind



SUPER BRIGHT
WASH RIGHT WITH SUPER BRIGHT

Complete range of Cleaning Chemicals



For Laundry

- **SUPER BRIGHT-HD-ULTRA**
For removing oil/blood/grease stains.
- **SUPER BRIGHT-WHITENER**
To improve reflectance of both coloured as well as white clothes.
- **SUPER BRIGHT-OPAL**
To clean heavily soiled fabric & imparts high cleaning properties.
- **SUPER BRIGHT-FABRIC SOFTENER**
With anti-static properties, it improves the whiteness or brightness of clothes.
- **SUPER BRIGHT-SOUR**
Removes excess alkalinity, chlorine & detergent from the cloth.

For Housekeeping

- **CRYSTAL**
Ready to use liquid glass cleaner.
- **SANITEX**
Sanitizer cum floor cleaner.
- **TILEX**
For tile cleaning.

Available Concentrated range for Glass /Floor / Toilet Bowl Cleaning.

Also available liquid cleaner for Dish Wash, Utensils, Crockery and for anti-germicidal treatment.

Ask for our detailed catalogue having information of 100 plus cleaning chemicals.



NAVIN POLYCON

Delhi Off.: 81, DSIDC Sheds, Scheme-I, Phase-II, New Okhla Indl. Complex, New Delhi-110020,
Phone: 26387377, 26386392, 26386507
Fax: 011-26386063 Mobile: 98102 59863
E-mail: navinpolycon@rediffmail.com
www.navinpolycon.com

Agra: M/s. Camex India, Ph.:0562-2620720 / 6541904 Mobile: 9837077627

Contact: Mr. Sachin Jain

Bangalore: M/s. Celestial Health Care, Mob.: 09343047197 Fax: 080-5504757

Contact: Mr. John Brito

Calcutta: Ph.: 033-24554959, 24551558

Contact: Mr. Vipul

Jodhpur: M/s. Chemtech Corporation, Mobile: 09829188885

Contact: Dr. A. Hussain

Dealers Enquiry Solicited



“Nothing brings more happiness than good comfort food”

Chef Utkarsh Bhalla, Brand Chef, Sly Granny



“Mostly what we have grown up eating is comfort food. Pasta and Pizza is comfort food for an Italian. Sushi and Sashimi is comfort food for Japanese similarly noodles and dimsum could be comfort food for a Chinese. Comfort food for me us what brings back Nostalgia especially memories of when I was young”

Chef Sahil, Culinary Head, VDeliver

us of home. Perhaps that’s why we tend to turn to comfort foods in times of stress. Diners like dishes that turn eating into an experience, and comfort foods do just that by offering a nostalgic experience.

Your Hot Selling Comfort Food

Altamsh Patel, Executive Chef, Oakwood Premier Prestige Bangalore

Being a chef it is our responsibility to study comfort food that works well and has a synergy with the menu you work with. Since I am in the professional of curating dishes and serving guests, I feel it is my responsibility to serve this comfort food with a modern touch to share and appeal to a wider audience. Khichdi, for instance, is one of the most common form of comfort food in India. So every time I make it, I try to experiment a little with either the presentation or a vegetable or change the lentil to make it a little exciting.

Another one of my personal favourites is, ‘Spaghetti Aglio e olio’. It is one of the more popular international dishes which hardly take 15mins to cook and is full of flavours. It goes very well with any meat or vegetables. It is a quick and satisfying dish and also one of the top selling pasta dishes in any Italian restaurant. This dish is a great example of using minimal ingredients to get a dish rich in flavour.

Sumit Sinha, Director of Food & Beverage, Crowne Plaza Today New Delhi Okhla

Kacchi Gosht Ki Biryani - Nothing can satiate your soul cravings better than a Kacchi Gosht ki Biryani. The wafting fragrance of the Biryani connects us back to festivities and celebrations. The meal is pre-marinated so that the flavours of spices seep in properly. The rice is then slow cooked in a handi along with meat and special condiments. Every morsel of this Biryani is a burst of flavours.

Another dish which is very popular is ‘Cannelloni Florentine’ - Cheesy Pastas are super comforting to the palate. In this particular dish, pasta sheets are blanched and rolled with sautéed spinach and cheese. The same is put on a bed spread with Bechamel sauce followed by gracious topping of Cheese. Finally it’s baked to perfection.

Chef Utkarsh Bhalla, Brand Chef, Sly Granny

Crispy chicken & fries - Juicy pieces of chicken are rolled in a homemade mixture of

buttermilk, cornflakes and flour before frying in a skillet. This gives the dish a crunchy and crispy exterior which pack in all the juiciness of the chicken. Every bite begins with a breaking of the skin to reveal the steaming hot and tender chicken inside. The fries serve to amplify the dish as a starchy accompaniment. The dish is served with in-house prepared hot sauce to provide a level of spice that the diner is comfortable with.

Meaty Aglio olio is another dish we serve. It is spaghetti tossed with all meats (ham, bacon, chicken, sausages, shrimps) cooked Aglio olio style. This used to be our meal at the end of a busy operation, where chefs would toss in all the left overs and used to eat it with garlic crostini.

Chef Sahil, Culinary Head, VDeliver

Pizza with chicken tikka/ paneer tikka toppings. Since companies like Dominoes and Pizza hut entered the market Pizza has itself become a part of comfort food. Now when you add Nostalgia like a chicken/ paneer tikka it becomes a wholesome comfort meal.

Your Own Comfort food

Altamsh Patel, Executive Chef, Oakwood Premier Prestige Bangalore

Dal Chawal! I believe it is not just a dish it’s an emotion. I grew up eating Dal Chawal cooked by my mom. As a child I never used to like eating vegetables so Dal Chawal was what I would eat more readily. It is also considered as a wonder diet. If consumed in proper portion size it is beneficial for health as well. Being a chef I am lucky that I get chance to cook and taste gourmet dishes but for me dal chawal will be my first love which I will always turn to, at the end of a long day.

Sumit Sinha, Director of Food & Beverage, Crowne Plaza Today New Delhi Okhla

I love to savour mixed Noodles and Kathi Rolls. They are wholesome and act like a meal in itself. They generally don’t even require any extra accompaniments. They have been my companion during the super hectic days of my Chef life when I didn’t get enough time to sit and relish a full meal.

Chef Sahil, Culinary Head, VDeliver

Simple rice and dal with phulkas topped with desi ghee and bhindi. Being a chef I get to taste a lot of food during tasting sessions. So this home cooked food is something I look forward to all the time.

2021



AAHAR

THE INTERNATIONAL FOOD & HOSPITALITY FAIR

APRIL 6 7 8 9 10

PRAGATI MAIDAN, NEW DELHI

HALLS 2 3 4 5 (Ground and First Floors)

Safeguards & Represents Interest of Members

HOTREMAI strives to safeguard and represent interest of its members in particular and of the industry in general by taking-up various issues adversely effecting the business of its members with the government bodies, hotels, restaurants and their associations.

HOTREMAI

THE HOTEL & RESTAURANT EQUIPMENT MANUFACTURERS ASSOCIATION OF INDIA

Business Promotion

Through its programmes and events: HOTREMAI organizes in-house meets, like Purchase Managers Meet, Hotel Consultants & Architects Meet, F & B Managers Meet, Project & Engineers Meet and such other events, where the representatives of the hospitality industry interact with its members, know their products and services, discuss the problems faced by them and make collective efforts for their effective solutions besides establishing mutual understandings and workout fruitful business deals. This provides its members a platform to demonstrate their products and services and provides opportunity to know their customers' needs.

Special Discounts

For its members, HOTREMAI facilitates with special discounted rates for participating in business exhibitions, fairs, shows and events organized by government and non-government trade and industry promotion bodies

Informative to its Members

HOTREMAI publishes a periodical journal known as 'HOTREMAI REPORTS' in its effort to be more informative to its members and the industry. It carries information on activities, happenings and developments in the hospitality and allied sector and also covers the information on new projects, exhibitions and events. This creates opportunities for members to actively participate by sharing their views and also advertise their products and services at nominal costs. The 'HOTREMAI REPORTS' is circulated free of cost in the hospitality industry.



Different Benefits, One Association !



The Hotel & Restaurant Equipment Manufacturers' Association of India

D-20, Local Shopping Complex, (Upper Ground Floor), New Rajender Nagar, New Delhi 110060.
Phones : 011-28745698 Mobile : 99100-48121 Email ID : info@hotremai.org Website : www.hotremai.org

Be a proud member of 'HOTREMAI' and enjoy the benefits of being together ...



Choosing the Right Tableware

Tableware comprises the dishes or dishware, which are used for setting table, serving food & beverages and for dining. Its wide ambit includes cutlery, glassware, serving dishes and other useful items. Tableware has utilitarian and as well as cosmetic appeal for the guests.

Buying tableware for a foodservice establishment is an important decision, often involving major investment. The right plates and cutlery can facilitate in bringing the right look to the restaurant's design. On the other hand, clumsily designed tableware or tableware which doesn't gel with the theme of the restaurant, can attract resentment among the discerning restaurant goers. We can say that procuring the appropriate crockery or cutlery can help in developing the image or branding of the

restaurant.

Tableware is an important component of the overall look of the dining area of the restaurant. The quality of tableware shows upon the efforts taken to leave an impression on guests that dine at the restaurant.



Tableware has been playing an important role in dining experience since ages, but in this post-modern age, where presentation of the food in the restaurant business has become almost as crucial as the quality of food itself, the role of tableware has assumed immense significance for the food service business.

When selecting your tableware, be sure to take the time to choose the right options that fit in to your restaurant's concept. It is important that the first impression is a memorable one that leaves customers eager to come back to your outlet again and again.

Most of the food service establishments favour white crockery since it is believed that food looks better on these large, plain dishes. Also at the same time against the blank canvas of the plate, the food's colour and texture can easily pop up, making it look more appetising. And it is a general belief that if food looks good, it is more likely to taste good too.

Though many prefer white plates but they are not exactly unique. It may be the convention across the Indian food services industry, but it is not innovative. If the restaurant has a profusion of matte colours in its decor, then huge white plates would look odd. Play with patterns, colour and shape. Even with white dinnerware, you can experiment by adding colourful accents or shapes to the setting. Think how you can

use your eclectic stash of crockery to reflect on your style of food, or on your specific ingredients. The right selection of the plates needs to be according to the dish being served. For example, risotto is apparently best served in a shallow, rimmed dish, so one can eat from the outside in.

To ensure that investment on the tableware works in a fruitful way, few aspects need to be kept in mind.

Budget

Most important aspect is to have a specific budget in mind and consider the value of your tableware purchases within that budget. But do not be too stingy on the pricing of tableware. While finalising the budget for tableware always remember that it is better to buy tableware with quality and durability even if they are a little more expensive as this could save you cash in the long-run. Great quality china will not scratch as much when stacked, as the bottom would tend to be smooth and more resistant to markings left behind by flatware.

Operators starting a new restaurant, or re-designing an existing one often forget to budget for tableware at the beginning of a project. And when it is time to choose tableware, they often realise they have overspent, and this could result in curtailing of the tableware's budget. This irresponsible practice must be abhorred by the restaurateurs or would be restaurateurs.

The Stock

Another key consideration is to know how much stock you need to keep, based on the number of covers in the restaurant. Mostly 130 percent of the required stock is kept to replenish as and when required. It is also a good idea to have few extra pieces in case of breakage or unexpected guests.

No one wants to invest in a new tableware product line to find out six months later that it has been discontinued. Check that your choice of crockery has good long-term continuity or ask about continuity guarantees from the manufacturer concerned. Before committing to a line, ask about lead times or local stocking dealers for delivery.

In Relation

The tableware of the restaurant must relate to the ambience, décor, theme and also to the food of the given restaurant. Mostly Chefs at the restaurant choose the tableware. They should ensure that the



tableware matches the ambience, theme, décor, and style and content of their food. Nowadays diners are increasingly looking for an overall experience when they come to the restaurant, which includes how a dish is being presented.

Ambience, lighting and décor set the scene before the food arrives, so in order to impress diners, select tableware within this broader context; not just based on how a dish looks with a given tableware. It is a good idea to take dishes out into the restaurant and see how they work from the diners' perspective.

Durability & Usage

Durability of tableware is important for business purpose but one shouldn't use the same crockery and cutlery for ages, which can give repetitive or boring look and feel to the dining experience. Nowadays diners may not like to dine in a restaurant where the crockery is older than the Chef of the restaurant and looks so too.

To achieve a middle ground, choose a

number of core tableware items which are great performers in terms of durability then select some tableware items that add more consumer interest but might not be highly durable.

Also choose your tableware while taking into account of your kitchen operations. If your restaurant serves some dishes on hotplates, go for choosing dinnerware that can withstand the high heat, and invest in underliners. Also shop for plates and bowls that are microwave-safe or oven-safe, which will be more durable and long lasting. If your culinary focus is on sizzlers and steaks, don't forget about Sizzle Platters, which are a great way to serve steaks, sizzlers and other piping hot cuisines.

Besides the longevity of the tableware, whether the design of the tableware can be sustained for a long period must be taken into account. The challenge involved in replenishing the tableware stock after breakage is another important factor to be taken into account while purchasing tableware.

There are other important factors to be considered while selecting tableware. For example, will the plates be cleaned manually or on dishwasher, the proper storage for the plates to make them last long, do the plates hold heat well so your meals don't cool down too quickly, are the plates too heavy, too wide, or too awkward to hold comfortably by servers are some of the factors to be taken into consideration while selecting tableware.

Going Touchless



COVID-19 has increased awareness of health and safety among people while they are travelling. Travellers expect hand sanitizers, disinfected public spaces and antimicrobial surfaces located throughout airports, lounges, restaurants and hotels. All of a sudden this is all on the table. The pandemic has redefined the need to reconsider how guests can interact with amenities. Reducing contact with commonly touched interfaces allows guests to stay safe and housekeeping staff to sanitize faster.

Not only have guests opened their minds to what the hotel experience can or should be like, they're also counting on properties to come up with new ideas, both for now and well into the future. One of the best ways to maximize the well-being and peace of mind of guests at hotels is to incorporate touchless hotel technologies in the property.

In many airports, it's no longer necessary

to stand in a queue to check in and people are expecting the same kind of easy, technology-driven check-ins at hotels. Guests want to be able to do everything from checking in at a venue's automated kiosk to ordering room service with a digital device instead of standing in queues and moving around the hotel premises to order food.

Hotel guests expect to be able to connect to the internet seamlessly and without too many interruptions, leading hotels to invest in better, faster Wi-Fi infrastructure so that people can do business and use their technology devices with ease when they book their stay. A touchless hotel decreases or eliminates the need for guests to interact with germ, unsafe surfaces as much as possible through smart hotel technology that automates common tasks or allows guests to use their phones for key tasks such as



check-in. Currently it is not possible to eliminate all touchpoints in a hotel, but one can eliminate most hotspots such as check-in and door handles. Few steps hotels must take to offer best solution for the minimum touch based property are:

Mobile Check-In / Out

Mobile check-in/ out hospitality tech is an important area to consider, because it can help to improve the customer experience at the point of their initial arrival and later departure. This is especially beneficial, because total impressions can have a huge bearing on how customers ultimately feel about their visit or stay.

Mobile check-ins swerve the need for face-to-face customer interactions, meaning customers can potentially have greater flexibility in terms of when they check-in. This ties in with wider contactless technology trends within the hospitality industry, and can be especially welcome for those who are nervous about COVID.

Contactless Payments

Contactless payments offer a number of advantages for hotels, resorts, restaurants, bars and cafes, which is why this has been among the main technology trends within the hospitality industry in recent times. Aside from speeding up payments and improving customer satisfaction, contactless tech is also easily compatible with loyalty programmes.

Mobile contactless payments are possible even if customers do not have their wallet with them, or even if their credit card has been misplaced. With COVID firmly in the minds of hotel guests and other hospitality customers, contactless payments can also offer an excellent way to reduce human-to-human contact.

Room Access System

Hotels are increasingly installing smart room access systems that allow guests to unlock their doors by simply swiping their phones across a keyless pad on the door. Provide key to a guest who can access right from their phone so they can wave it in front of their door and easily unlock it without ever touching the handle. Digital room keys that allow guests to unlock doors using their phones thus are gaining renewed interest. Another innovative way to offer a keyless experience is through fingerprint-activated room entry systems and retina scanning devices. Retina

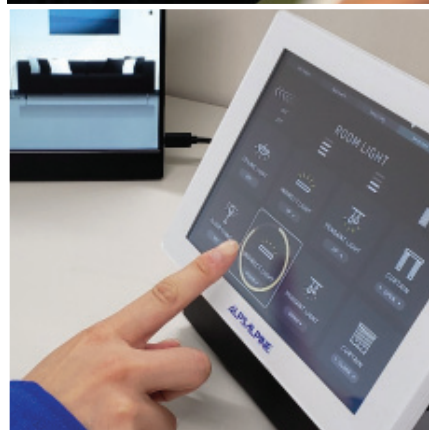
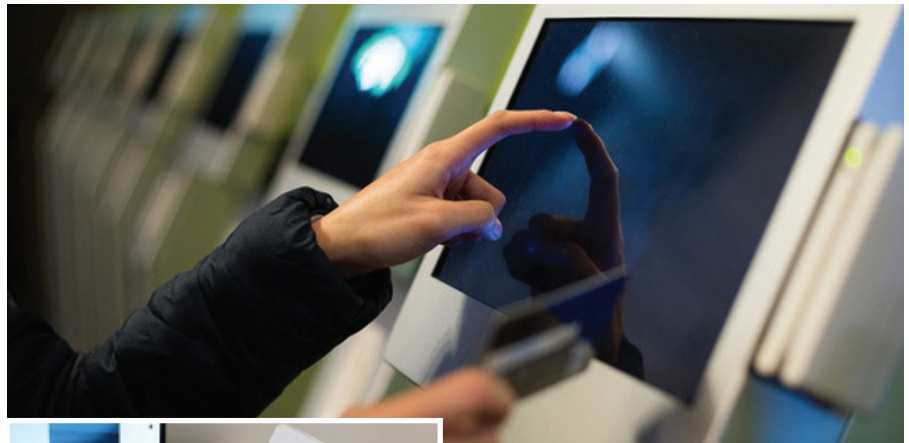

scanning is even more accurate and secure than fingerprint scans and few hotels have already installed an iris scan system in place of key cards to control access to the hotel's suites.

Recognition Technology

Recognition technology is one of the most important emerging tech trends in general, but its potential uses in the hospitality industry are especially interesting. In particular, biometrics is being used to usher in a new age of seamless authentications, and this could benefit hotel processes and customer purchases.

For example, imagine if a fingerprint or facial recognition technology could be used in your hotel to unlock rooms. Now consider the uses of the same technology for check-in and check-out purposes. In the future, this technology is also likely to allow for completely seamless purchases, with payments being authenticated by touch.

Automation

Automation can improve occupant health and productivity optimization of interior environmental conditions, optimized resource use and management, improved building security and safety, improved sanitation.

Few activities can be undertaken by

properties for touchless operations are:

Motorize Blinds

Support sanitary drape raising and lowering practices by offering a combination of app-based and voice controls for them.

Motion Sensor Faucets

Install motion sensor faucets in guest rooms, public bathrooms, spas, gyms, and kitchens to completely eliminate one of the high concentration germs areas.

Touchless Elevator Technology

Hotels can put antiviral stickers for elevator buttons or the operators can run elevators, express service for each elevator ride. Even hotels can provide elevator buttons that riders can activate with their voice or hand gestures.

Wireless Phone Chargers

Choose a tool that offers the highest disinfectant capacity with a peak-effect wavelength to destroy harmful bacteria on phone surfaces while juicing up batteries.

Voice-controlled TV

Use voice assistants made by companies such as Google and Amazon in rooms. Then, sync them with televisions so guests can search for movies, bring up their favorite streaming service, and adjust the volume without having to touch a remote in the process.

Motion Sensors

Motion Sensors that turn on lights, to voice-activated control of appliances

IoT Devices

Another technological trend within hospitality management is the 'Internet of Things', or IoT, involves extending internet connectivity to everyday objects, devices and appliances. These devices can then collect data and communicate or interact over the internet, turning previously unintelligent devices into 'smart' devices, which are often semi or fully autonomous. ■



Exhaust Systems

Ensuring Good IAQ

Hotels generally are large properties which generally have the presence of a large floating population of guests with a substantial number of in-house employees. Restaurants in hotels as well as stand-alone restaurants too have a large floating population of guests, and an array of staff.

Due to space constraints and to minimise capital expenditure, hotels and restaurants in urban as well as non urban areas are mostly constructed on a modest area of land where the management tries to fit in as many facilities as possible. One such facility is the exhaust system.

For Comfort and Safety

Exhaust system plays a very vital role in maintaining the freshness of air for guestrooms, kitchens and restaurants, and also regulates the overall ventilation system. Exhaust systems remove odours and this process improves indoor air quality, which

also includes indoor air quality of restaurant kitchens.

A restaurant kitchen or any other commercial kitchen, due to the presence and use of burners, stoves, boilers, etc. has the potential to generate a great amount of unwanted fumes, vapours and odours which are required to be eliminated from the air, in order to safeguard the health of the staff and as well as the guests.

In this regard, an exhaust system is of crucial importance. Without a good exhaust system, a restaurant kitchen or any other commercial kitchen is expected to have lots of harmful fumes and smoke, and the heat in the kitchens would be unbearable. All these would lead to extremely uncomfortable and hazardous conditions for the kitchen workers and as well as the guests.

Exhaust systems are of great importance for modern kitchens of today. They keep away fumes and vapours and stop smoke

generation. So, a proper working exhaust system holds the key to a good and clean kitchen, and creates proper working conditions for the kitchen staff.

AC Factor

Moreover, these days most of the decent hotels and restaurants are air-conditioned; keeping in mind the discerning tastes of the guests. In such a scenario, ensuring pure and fresh air quality, proper ventilation and keeping the kitchens properly aerated is an important task.

In any dedicated air-conditioning system, a good exhaust system is of prime importance. Since in AC systems, the treated air generally moves in via ducts which are fitted in different floors of the hotel, exhaust systems play a vital role in treating and purifying the air. Exhaust system is an essential part of HVAC. To keep the air-conditioned areas fresh and ventilated we have to provide the system with supply of

Operations

fresh air and exhaust air as per the design parameters of HVAC.

Features and Installation

Exhaust systems must be located in open and spacious areas so that they can have easy access to clean and fresh air which can then be cooled and pumped in the hotel rooms. It is important that the area surrounding the exhaust system is clean and there are no unpleasant odours and it is free of smoke, smog, or dust. Exhaust system must be accompanied with appropriate supply of fresh air. The main advantages of exhaust system are that it enhances the freshness of the area.

The exhaust systems come with a number of key features, advantages and benefits. For the main kitchen, with two speed exhaust motors, one can adjust as per the requirement, depending upon the kitchen load. Duct cleaning for the main

outlet. After that, check the direction of blower, sound levels and labeling of the exhaust system. The usage areas, location, load factor, and environment friendliness including energy efficiency, are the key factors which need to be taken care of while installing an exhaust system.

Hotels and restaurants are constructed across different geographies, on different sizes of plots and in different architectural styles. The type of exhaust system to be used depends on these factors too.

Choosing the Supplier

Different types of exhaust systems are available in the market and there are a number of different dealers and suppliers for the exhaust systems. However, choosing a dealer or a supplier of an exhaust system is an expertise in itself and requires careful planning and approach. Refer to various applications for which exhaust systems are



kitchen should be done on yearly basis as per ISO-22000 and fire safety norms. Also the exhaust air generated from kitchen & generators should be connected to wet scrubber to prevent air pollution. Record stack temperature of machinery to monitor their efficiency on a regular basis.

Installation of exhaust systems is a complex task and requires a high degree of expertise and engineering skills. For the main kitchen have separate exhaust with exhaust hoods in areas. Sound level of the exhaust, its installation process, energy efficiency of the unit, area required by the unit, the length of ducting are only some of the factors which should be kept in mind while designing the exhaust systems. Exhaust system for main kitchen is normally accompanied with treated fresh air as per designed ventilation system.

For installation of the exhaust system, first check the load of the installation process, and connection of inlet and

required, based on the inlet air quality and various installation factors.

Choose supplier based on his work capacity, availability of options, product technology, the quality of the exhaust system that the supplier is offering, product life, energy efficiency, how the system fits into required applications, its warranty and costing, etc. Also past performance and client list should be used as criteria for choosing a given system.

The supplier should have authorised dealership of the exhaust system. He has to take the ownership of the after sales service after the proper installation and commissioning, and last but not the least the rate must be competitive. When looking for choice of the exhaust systems, scrubber exhaust system is ideal for restaurant kitchens.

Thus while buying an exhaust system, check factors like efficiency, quality and after sales service and energy consumption factor. ■

MISTRY ASSOCIATES HOTEL CONSULTANTS

- Planning of Kitchens for Hotels
- Facility Planning / Designing of Back Of House Areas for Three to Five Star Category Hotels
- Designing of Hospital / Institutional / School Kitchens and Cafeterias
- Designing of Bakeries and Confectionery Units



**Awarded
HOF
Icon Kitchen Consultant
Western Region**



**30, Mistry Court, 208, D. Vacha Road,
Mumbai - 400 020.**

**Tel.: +91-22-22026374, 22875459,
9820284193, 9819435155**

Bengaluru Office: +91-9945519050

**E-mail: imtiazmistry@gmail.com
imtiazmistry@rediffmail.com**

www.mistryassociates.net



Ganga Kinare - A Riverside Boutique Hotel

Soulful Stay at the Charming Retreat!

By Sharmila Chand

Located right on the banks of The Ganges, 'Ganga Kinare - A Riverside Boutique Hotel' is a charming retreat in the blissful destination Rishikesh, a land where travelers get to experience a beautiful mix of spirituality and Mother Nature. The luxurious property, established in 1986, provides guests with unparalleled views of the tranquil river and the greens of the Rajaji National Park, one of North India's expansive sanctuaries and a melting pot of diverse flora and fauna.

On arrival at the spacious lively lobby, guests are gently welcomed in a traditional style with Aarti and Tilak as a blessing from

the The Ganges, and this sets the tone for a perfect feel of a home away from home.

Accommodation

The boutique Resort boasts of well-appointed rooms & Suites equipped with all modern amenities to fulfill guests' needs.

Lotus Suites are approx 550 sq. feet in size, on the highest floor of the hotel, these suites have been thoughtfully designed with space efficient straight line furniture and comfortable four poster beds with all modern day amenities. They have the grandest view of the holy river Ganges and the Rajaji National Park. The room

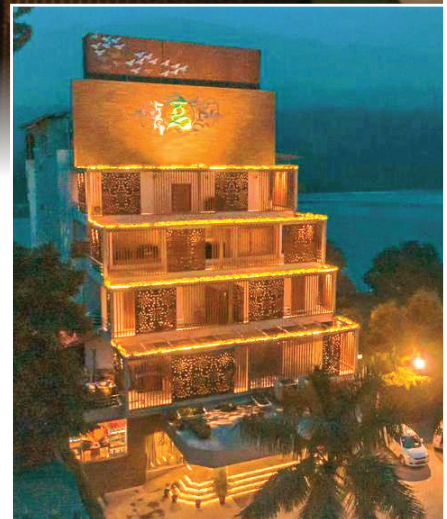

has designated dining and living area with spacious bathroom having bath tub and shower space.

Premium Rooms are 320 sq. feet rooms having 180° uninterrupted view of the Holy River Ganga and the forest. These rooms are tastefully decorated in warm tones, lending an inviting feel to the room. Offering a Queen size bed, air-conditioning, a TV with satellite channels, wardrobe and 24-hour room and laundry service, these rooms are ideal for leisure travelers.

Family Room is aesthetically designed, well-ventilated, 430 sq feet with two queen sized double bed offering a plethora of high-end amenities. The room looks very inviting with warm colour tone and provides all modern day amenities.

Dining

Jal & Jalebi – All Day Dining: A lively multi-cuisine restaurant serving comfort food and continental delicacies, with al fresco dining areas, is the talk of the town. Donning the



look of a snug and sunlit riverside eatery by day, Jal & Jalebi metamorphoses into a candlelit gourmet dining lounge in the evening. The riveting panorama of river, greens and the mountain range looks beautiful through the windows and spill into the lounge. The service is very warm and personalized. They take care of every guest's needs and curate menus accordingly.

Yoga at The Retreat: As Rishikesh is India's most sought after yoga destination, the property offers Yoga and Meditation sessions at Yog Ganga, Rooftop Meditation and Yoga Hall, in the perfect setting by the The Ganges with the backdrop of the Shivalik mountains. Guests can take group workshops or daily morning lessons and can choose from a range of basic to complex routines for the experienced.

Ayur Ganga Spa: Guests looking for relaxation can opt for a spa therapy as here the therapists have expertise in traditional and international spa regimes. Ayurvedic spa treatments are offered that are customized to guests' particular needs. The spa is well equipped with a steam room, pleasing interiors, original Kerala massage beds, authentic in-house massage oils and to top it all – a professional and highly trained team to provide authentic Indian and western massage therapies while ensuring the highest standards of hygiene and warmth.

Activities

Take a Stroll or Enjoy at the Gaming Zone:

For family free time, guests can indulge in board games or try a hand at playing Table Tennis and Football. The best way to relax is take a walk alongside the river, soak in the sight of the mountains, forest and revel in the sheer cornucopia of the surroundings.

Open Air Whirlpool at Machan: Relax over a nice latte at the Open Air whirlpool at Machan, the resort's mid-level terrace amidst the natural lush surroundings during the day or under the star-lit sky at night. Spend your evenings watching a picturesque sunset from here with unparalleled views of the Ganges and the forest beyond.

Private Ghat: Ganga Kinare by Holywater



Passionate & Methodical Hotelier!

Ankit Rawat, Cluster General Manager, Hotel Ganga Kinare



Driven by passion, Ankit Rawat, Cluster General Manager, Hotel Ganga Kinare in Rishikesh, has been a dedicated hotelier since past two decades. He has worked with well known brands like The Ritz Carlton Bangalore, JW Marriott, Chandigarh and Marriott Harbour Dubai, amongst others. The crucial positions in several locations across the globe have helped him in honing his skills in managing complex assignments and delivering higher yield by maximizing

on department's tangible resources; turning ideas into logical strategies and implementing systems that optimize productivity and deliver higher customer satisfaction. He firmly believes in creating positive and productive work culture, where every individual feels cared for and respected.

In an exclusive interview with **Sharmila Chand**, he talks about the distinguishing features of the property, his working mantra and more...

What is the USP of your property?

We are 35 years old well established renowned standalone brand in the city serving guests with the aim of offering unforgettable experiences of traditional spirituality. We are proud to have history of hosting well known saints, Yogis, spiritual seekers and celebrities in our hotel.

We are one of the rare properties to have beautiful temple within our hotel premises and a private Ghat to seek Ma Ganga's blessings. Hence, our guests are able to get Divine experience as we have regular spiritual activities like morning and evening Aarti where all can join. Our private ghat is the peaceful spot where guests like to spend time and offer their prayers. We also organize Yoga and Meditation sessions regularly. The soft music of mantra chants and traditional welcome of Aarti and Tilak for every guest is our way of creating good vibes in the property and wishing all guests Health, Wealth and Prosperity.

Our hotel is a rare combination of providing seamless luxurious, modern 5-star comforts, personalized services and

traditional experiences. The location of the property is again our USP – embraced by The Ganges and Rajaji National Park. Guests can enjoy the vast vistas of amazing landscape through their rooms, gardens and other areas in the hotel.

Our F&B department is our significant USP. We serve pure vegetarian and Satvik food. We prepare our own sweets made of pure Cow milk which we purchase from the cowshed adopted by the hotel. At the same time we have the vast menu of Continental and Chinese cuisine as well. So the guests have good choice to dine in style.

Our in-house Spa 'Ayur Ganga' offers signature wellness therapies and programs to guests for their relaxation and rejuvenation.

What would you say is the 'Differentiating Factor' of your F&B outlets?

We are very proud to serve the authentic thali of Uttarakhand – 'Garhwali Thali' where we have tried to source all ingredients from our region and prepare dishes in the traditional way. One of our local dishes of the

Hotels enjoys a location like none other. Situated right on the banks of the holy river Ganga, this hotel is blessed with its own private Ganga Ghat and is the only hotel in Rishikesh that is blessed with such close uninterrupted proximity to the holy river. Regular meditation and yoga sessions are conducted at this spot. The hotel also organizes daily morning and evening Ganga Aarti at this private ghat. Guests who wish to take a dip in the holy river can do so. The hotel arranges bathing robes and life jackets as an exclusive service.

Ganga Aarti at the In-House Temple: The retreat offers complete spiritual immersion everyday at sunrise and sunset. The ceremony commences with the singing of bhajans, mantra chants and Aarti – it is truly a magical experience when the lamps are lit and in-house priests let all guests join in the rituals.

Holywater by Ganga Kinare

Holywater by Ganga Kinare is the sister property of Ganga Kinare, located only 150 m walking distance from the main compound. Guests can also call it the annexe of Ganga Kinare. While this property caters to budget travellers, guests at Holywater can also enjoy all the inclusions of the main property Ganga Kinare like Private Ganga Ghat, Ganga Aarti and much more.

Prasadam at Varr

'Varr', fine dining restaurant offering 'Temple Cuisine' of India, has been launched at 'Holy Water By Ganga Kinare' recently. Guests are taken on an exclusive culinary journey with an array of dishes served as thali menu. Each dish signifies 'Prasadam' of a specific temple. For example, there is pavakkai pitlai, a bitter gourd curry and puzukhu made from ripe jackfruit and black chanas, to mangai kosamalli, javarisi paal payasam, served across temples in South India and bhoger khichuri from Orissa to langar di dal of Golden Temple, Amritsar and the poori chana of Vaishno Devi. The team has sincerely maintained the authenticity of ingredients in cooking the pious offerings, true to the temple and the region recreating the original experience for every Atithi.

Overall, the property blends elegance and simplicity beautifully to create a memorable holiday experience. Due to all luxurious comforts, warm hospitality and doting staff, no wonder guests and many celebrities come here regularly for exclusive immersions. ■



region, 'Singori' dessert wrapped in herbal plant's leaf, again famous of Uttarakhand, is our showstopper in our all day dining restaurant, 'Jal and Jalebi'.

We have recently launched a new restaurant at our sister hotel, Holywater. It is called 'VARR' where we serve temple food encompassing the entire country. It is an immersive experience for the diners to partake temple food and get the feel of the culture and traditions of various regions of India.

Could you reflect on the future plans and new initiatives you wish to undertake in your property?

As stated earlier, we are one of the rare hotels in the country which is preserving the culture of Gadhwal and spiritual tourism. My endeavour is to enhance the guest experience by offering more Satvik food menu, encourage visitors to join our wellness programs and Vedic Lectures.

Also, we are coming up with new properties in the city soon with the unique concept of Wellness and encouragement towards spiritual tourism.

What is the most crucial issue to tackle in the Hospitality industry today?

Potential and professional manpower is tough to find and retain. I see that the new generation opts for hospitality sector with big dreams but lose their enthusiasm once they are at the job. As the hotel industry serves guests 24 hrs round the clock, so it is very much expected from a hotelier to dedicate long hours at work. But I have observed that the youngsters are not able to sustain for long.

What do you enjoy most about being at the helm of affairs at the hotel?

Meeting new people every day and serving them gives me immense satisfaction. Creating personalised memorable experiences for my guests is very rewarding for me. Also I enjoy coaching associates towards achieving their mission in their job and help them to win where they falter.



What has been the most rewarding moment in your career?

There have been several rewarding moments in my career as a hotelier as I have worked in several locations in critical positions. Presently, the position of 'Cluster General Manager' of historical Riverside Boutique Hotel- Ganga Kinare and Holy Water By Ganga Kinare, in the most pious city Rishikesh, is what I cherish every day. I am truly blessed to be serving guests here which is also my hometown, what could be more rewarding than my present state of mind.

How do you de-stress?

I practice Maun (Silence) Hours daily. It can be called my Meditation mode but personally it works like serene blessings for me. This practice helps me to maintain a balance in my daily life.

What is your working Mantra, your guiding philosophy in work?

Be focussed towards achieving results and do not press Pause button as moving forward is the only road towards reaching your destination. Keep things simple as they are but perceive towards the best you can do. Learn something new every day. Meet a new person everyday and stay connected with those who inspire you and make you laugh loud without any inhibition.

One advise you would like to give to youngsters aspiring to excel in Hospitality?

Visit a fine dining restaurant or plan a vacation in a good hotel. If you feel thrilled and curious about the details and the way a professional hotelier serves you then you are the right person to pursue a career in the hospitality industry.

Also a good counselling from a seasoned hotelier would definitely help you in asking yourself, "Am I Right for This Job". If your answer is a clear and loud 'YES' then you are ready to take a plunge into Hospitality. Let it not be an Accidental Choice, then only you will be able to sustain it in the long run.



Invites Participation
in the 36th edition of
Aahar 2021

45%
Reduced
Tariff than
last Year

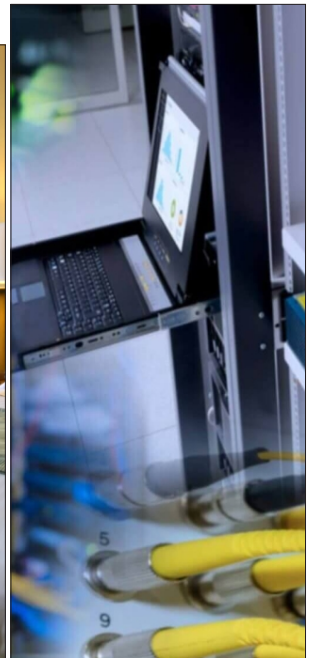
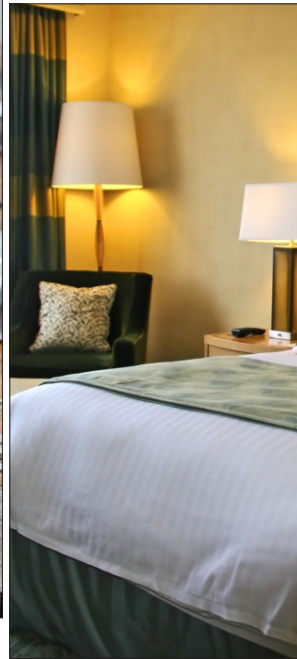

Product Displays

Food & Beverages • Processed Food • Food Ingredients
Food Processing Equipment. • Packaging Machinery
Restaurant & Kitchen Equipment • Cleaning & Hygiene • Interior & Furniture
• Hotel Design • Bakery Equipment & Supplies

ARCHII is well recognized platform to discuss the possible arrangements, contracts, dealings between member's interest to regulate and standardize as far as ethical business practice in the hospitality trade.

ARCHII arranges, sponsors and support various conferences, exhibitions. It promotes goods/equipments by arranging meeting and one to one discussions with multiple invited high profile visitors and guests.

ARCHII has been actively involved with ITPO to organise Culinary Show & Seminars at previous edition of Aahar

For Space Bookings & Good Location, Contact : Mr. Vijay (Sec.)- 9506315924, Ms. Bharti (Ex. Sec)- 9871582149

Association of Resource Companies For the Hospitality Industry of India

LB 2/2, Manu Apartments, Mayur Vihar, Phase-1 New Delhi-110091

E-mail: archii.association2020@gmail.com | archii.association@gmail.com

Website: www.archii.org



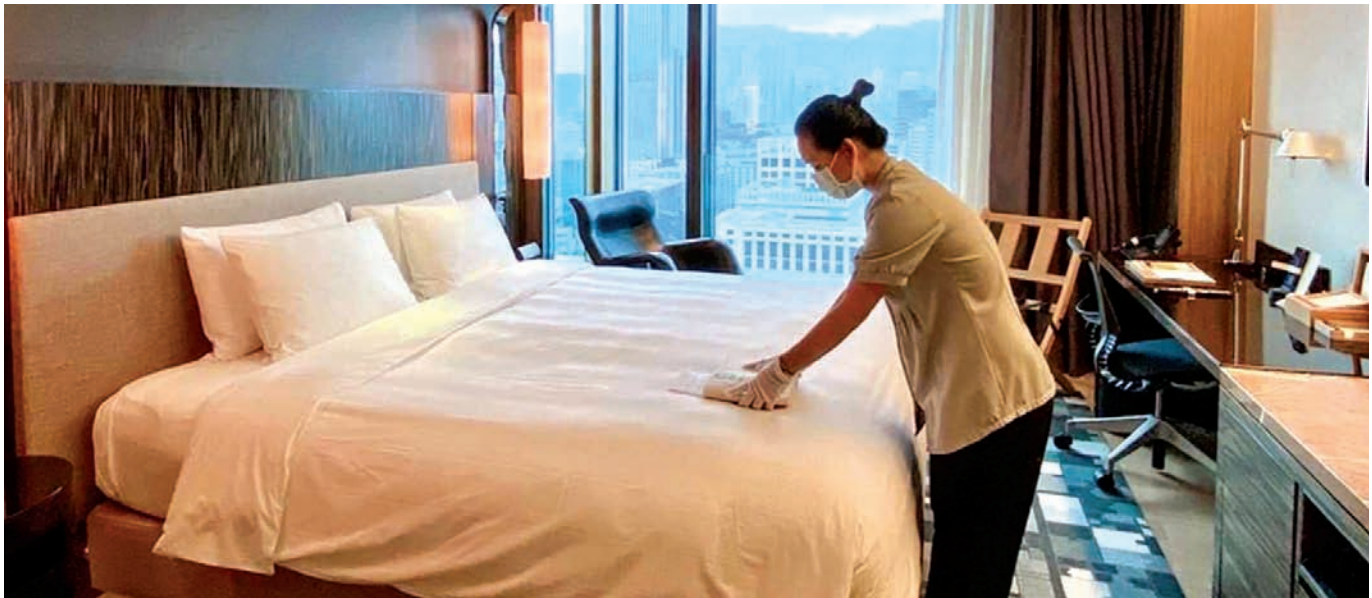

New-age Housekeeping in Hospitality

By Jhuma Biswas

Housekeeping is an important edifice of hospitality and the experience of this global pandemic has undoubtedly enhanced its importance further. In fact, the Covid times and its shadow are expected to influence the housekeeping in the hospitality sector for a long time. Besides ensuring comprehensive government directed sanitisation and hygiene protocols, digital check-in and check-out, and e-newspapers and e-magazines are expected to become the norm in India's organised hospitality sector.

Comprehensive Care

The staff of the housekeeping department in a hospitality property starts taking care of the guests even before their arrival, for example by preparing the rooms for them. And their role pertaining to the guests can extend even after the guests leave, for example by replenishing the toiletries in the room where a given guest stayed.

The core responsibility of housekeeping



staff in the hospitality properties like hotels and resorts (for that matter in any property) is to maintain hygiene and sanitation in the properties, but in today's post-modern day housekeeping, that is often not the only responsibility of the housekeeping team in hospitality.

Personalised Hospitality

If Covid has made housekeeping standards in hospitality more stringent and accountable, the digital wave has the potential to make housekeeping for India's hospitality sector much more personalised.

Nowadays the Executive Housekeeper and her/his team can easily keep a track of the habits, favourites and dislikes of their frequent guests or even of those guests who have visited their place twice or thrice by maintaining a detailed guests' data base in the computers, where their likes, dislikes, preferences can be meticulously recorded. Preferences and dislikes for new guests can also be collected through an intelligently

designed but simple Q&A form at the time of check-in.

Digital technology helps ensure that the housekeeping staff in hospitality properties is continually updated on guests' preferences and dislikes. Creative usage of these information in an array of housekeeping services (of course, in other hospitality services too these information can be effectively used) can lead to more number of satisfied guests in the long-run.

This could enable the hospitality properties' housekeeping personnel to give their guests pleasant surprise (for example, by sending a bouquet of roses on the guests' birthday or marriage anniversary if by any chance those days fall during their stay at the property) and remove untoward irksomeness (for example, by adding a personal touch to room settings, removing a toiletry to whose fragrance the guest is allergic) among them, which in turn can facilitate their repeat visit/s to the same property.

Succinctly, prior knowledge about your guests, which is afforded by digital technology, can help to develop tailor-made services for them, which in turn can enhance the standards of housekeeping in hospitality and guest satisfaction together.

Security Concerns

Housekeeping staff in hospitality industry can also contribute towards facilitating the preventive security concerns of the hospitality properties. It is most likely that among all types of staff of the hospitality properties, housekeepers tend to interact the most with the guests and in turn are most probable to gain their trust comparatively quickly than other types of staff at hospitality properties. Across departments, housekeeping staff is likely to have the most access to assets and guests of a given hospitality property.

Because of all these factors housekeeping personnel are potentially well-equipped to notice if something is amiss or suspicious and they can also promptly report the matter to the right authorities. If housekeeping personnel are trained to do so on regular basis they may prevent something untoward from happening in real life and thereby facilitate safety of the guests and staff.

It would do hotels, resorts and other hospitality properties quite a lot of good if they train their housekeeping staff to become eyes and ears of the hospitality properties in real sense.



the threat to company assets," noted one senior housekeeping personnel.

Robots in Housekeeping

One of the byproducts of the digital age is the fast approaching robotic age. In future robots have the potential to solve the manpower problem in India's housekeeping sector. Hotels and resorts may find investing on robots for some mundane mechanical housekeeping tasks more cost-effective in the long-term than outsourcing to a housekeeping firm.

Yes, in some housekeeping jobs where personalised touch is crucial (like greeting the guest warmly or placing her/his favourite flower in the room in the morning or educating her or him on how to use safety lockers in the room), human beings have distinctive advantage over robots but for some other jobs where immaculate efficiency is more important (like making the common toilets in the hotel or the lobby area of the hotel germ free, floor cleaning, etc.) robots have advantage.

So there is no reason to not believe that with the advancement of robotic technology, robots would replace some form of human resource in the housekeeping departments of India's hospitality industry, in the near future.

In fact, I wouldn't be surprised if already a few of the high-end hospitality properties in India are using robots for a number of mundane tasks. However, the usage of robots in housekeeping and in other departments of the hospitality properties should be done in a way so that element of personal touch, which is the essence of hospitality, is not unduly compromised.

Pipeline to Success

Established in 1995, Delhi-based R R Sales Corporation has positioned itself as an eminent service provider of LPG pipeline installation Services. The company deals in LPG/PNG pipeline installations and kitchen ventilation (fresh air unit & exhaust). This sole proprietor firm has a huge number of clients.

The services of the company are tailored to meet the requirements of the company's clientele and are stringently based upon industrial norms and ethics. The product range of the company includes blower, scrubber, exhaust hood, fresh air system, fresh air washer, exhaust blower, axial fan among others. The impressive product range of R R Sales Corporation is complimented by its skilled workforce. The company places considerable emphasis on research and development and regarding this, has recruited a special panel for research and development.

The ethical business policies and customer-centric approaches are the cornerstones of the company and have facilitated it to develop a huge client base on a nationwide basis.

R R Sales Corporation

tarun.rrsalescorporation@gmail.com



Guestroom Supplies

Established in the year 1975, "Modern Cosmetic India" is recognized among the noteworthy manufacturer and exporter of a broad assortment of Hair Shampoos, Bathing Gel, Herbal Shower Gel etc. The company also deals in third party manufacturing and contract manufacturing of products. These products are manufactured with modern technologies and skilled workforce. Due to their optimum quality these are highly acknowledged by their clients. To cater the bulk order requirements of the offered products, they have developed a highly efficient infrastructure unit at their premises. All units are operated by experts, who are well-experienced and versed in their respective domains. Furthermore, the sound storage capacity enables them to keep ready stock to meet the bulk and urgent requirements of the clients. As a result of quality assured products and timely delivery schedules, they are able to build a huge client base, sprawling across the market. They also export products in Oman.

Modern Cosmetic India

moderncosmeticsindia12@yahoo.com



Serving Hospitality in Style

True to its image and the lifestyle of its clients, Mehta Furnishers continues to remain a preferred brand among the hospitality professionals. By combining art and utility, the company reflects a distinctive aura of excellence in its products.



With rare passion, supplemented with thoughtful, creative and proactive approach, the company takes care to meet up even the not so usual needs of its demanding clients. Over the years, Mehta

Furnishers, which has served major hotel brands for the past 25 years, has earned the well deserved reputation of being a trend setter in the field of wicker arts. Started as cane furniture company in 1984, Mehta Furnishers has diversified to various need-based cane and wooden products for various segments of hotel supplies.

Famous for its customised multi-utility wicker baskets, amenity aids for guest rooms and spa, trays, trolleys, caddies, and F&B service aids, the company is into cutomising a range of products. The new Housekeeping Trolleys and Mobile Caddies from Mehta Furnishers are set to raise the bar for mobile platforms in the corridors of boutique hotels, where aesthetic appeal is valued. The products are trendy, user-friendly, workably priced for the value they deliver and what's more, are environmental friendly. With this new range those huge service stations in the hotel corridors are set to become a thing of the past.

Mehta Furnishers

mehtafur@gmail.com

Adjustable Salamander

Machines for reheating pizzas, grilling continental dishes, sausage rolls & others and defrosting readymade dishes is preferred series and highly desired in the industry. So AKASA has come up with the Adjustable Stainless Steel Electric Salamander, With a choice of cooking heights (adjustable travel distance of 200mm), chefs have precise control over heat intensity and heat distribution. This also brings the added benefits of significant energy saving and a cooler kitchen ambience as heat is far more focused than with a static salamander. The unique features and flexibility of the Akasa's New Adjustable Salamander make it easy to operate, energy efficient and highly functional in any kitchen. Self balancing grill height and temperature control functionality allows for precise cooking of every item, with specially designed ergonomic operator control knobs designed to minimize liquid infiltration. With the capability to cook, grill, hold and reheat its ideal for your banquet, hotel, restaurant, food court or any food outlets



Akasa International

akasaintl@gmail.com

6 PCS KNIFE BAG



9 SLOTS KNIFE ROLL



Remington
KNIVES

+91-9810023928
+91-9910017678

remingtonsteelarts@yahoo.com
www.remingtonsteelarts.com

9 SLOTS KNIFE ROLL
FOR BAKERY



6 SLOTS KNIFE ROLL



ADVERTISER'S INDEX

<u>COMPANY</u>	<u>PAGE NO.</u>
ARCHII	47
ARS GLOBAL TEXTILES	15
CHARNOCK EQUIPMENTS PVT. LTD.	05
CREMICA FOOD INDUSTRIES LTD.	BIC
FAGOR INDUSTRIAL S. COOP.	07
GLOBAL LINEN COMPANY	27
HOTREMAI	37
IFB INDUSTRIES LTD.	11
INFINITY HYGIENE CARE	08
ITPO	01
LAXMI BRUSH COMPANY	12
LOOMCRAFTS FURNITURE INDIA PVT. LTD.	09
MEHTA FURNISHERS	13
METRO PLUS LIFE STYLE	25
MISTRY ASSOCIATES	43
MODERN COSMETIC INDIA	06
NAVIN POLYCON	35
PLATINUM BEDS INTERNATIONAL	21
PUSHKAL TEXTILS	33
RANS TECHNOCRATS (INDIA) PVT. LTD.	17
REMINGTON STEEL ARTS	50
R R SALES CORPORATION	10
S K INTERNATIONAL	23
STACKWELL	29
VEDIC AROMA LAB	FIC
VISTA HOSPITALITY SOLUTIONS	51
WINTERHALTER INDIA PVT. LTD.	BC

VISTA

your source for hospitality needs

feel secure with style

- Electronic Lock • Minibar • Digital Electronic Safe
- Customized Keycard • Automation System • Organic Waste Converter
- Intelligent Touch Panel Switches • Connectivity Panel • Docking Station
- Guestroom & Housekeeping Amenities • IT Solutions



Our Valuable Clients

- MEHRA HOTELS • LEMON TREE • CITRUS • RADISSON • RAMADA • CIS
- TAJ HOTELS • CROWNE PLAZA • COURTYARD MARRIOTT • HYATT • FORTUNE • VITS
- INDIA HABITATE CENTRE • JAPYEE GROUP • SAROVAR • ROYALTON • FERN HOTEL
- CITI RESIDENCI • ALPINE • SAVERA • FERN HOTEL • BEST WESTERN HOTELS • ANANTA RESORTS
- PACIFIC GROUP • CLARKS INN HOTELS • LE MERIDIEN • NOVOTEL

International Partners



VISTA HOSPITALITY SOLUTIONS

2389 GF, Hutson Lane, Kingsway Camp,
Near GTB Metro Station, New Delhi - 110009 India
Tel: +91 11 4612 2883, M: +91 95991 97962 / 66, 98710 20651
Email: info@vistahospitality.co.in, Web: www.vistahospitality.co.in

..... Serving Across Nation

- Delhi • Mumbai • Pune • Chennai • Bengaluru • Hyderabad • Cochin
- Ahmedabad • Lucknow • Patna • Shillong • Siliguri

“I believe in a Guiding Rather than Managing Approach”

Sascha Lenz, General Manager, Park Hyatt Chennai



Sascha Lenz is originally from Germany started his career in 1999 with Starwood Hotels and Resorts. Later he joined the Mandarin Oriental Hotel Group in 2004 at the Kahala Mandarin Oriental in Honolulu, Hawaii and was soon transferred to Hong Kong as part of the opening team of the Landmark Mandarin Oriental, Hong Kong in 2005. Sascha's career with Hyatt began in 2007 with Grand Hyatt Berlin as the Assistant Director of Food & Beverage. He subsequently moved to Russia to assist with the opening of Hyatt Regency Ekaterinburg in 2009 and later transferred to Hyatt's first Andaz brand hotel at Liverpool Street in London during the Summer Olympics in 2012.

He moved to India and joined Grand Hyatt Goa in 2016 as Executive Assistant Manager. Park Hyatt Chennai happened 3 years later and is his first assignment as General Manager.

In an exclusive interview with **Sharmila Chand**, he talks about his working mantra and more...

What is the USP of your property?

It has close proximity to airport and corporate hubs. It offers one of the largest guest rooms (43 sqmts) in the city. It provides unique residential style meeting spaces with ample natural light from ceiling to floor windows. It has Award winning Antahpura Spa & Pet friendly rooms.

Award winning food & beverage offerings:

The Flying Elephant Restaurant and Bar - designed to invoke a theatrical indulgence of Global Cuisines

The Dining Room - all-day dining outlet

What is the green initiatives hotel has taken?

Use of 20% of power from wind energy (renewable energy); solar panels to light up the hotel compound; rain water harvesting; optimization of HVAC system with help of building management system & chilled water automation system. Recently installed highly energy efficient chiller, cooling tower & pump

What is the marketing strategy to promote the property?

The property thrives on repeated clientele who are used to the finer things in life and appreciate the serene and tranquil environment. To continue to market the hotel we use a creative mix of channels in print and digital media. With the world moving more towards the digital space we utilize social media extensively because of its fast and better reach to the right profile of guests we wish to target.

What distinguishes your property from others in the same bracket?

Our people, Our Purpose – We care for people so they can be their best.

Our product - a tranquil retreat for the luxury traveler.

What the future plans and new initiatives you wish to undertake in your property?

We have already started our journey to become more energy and resource efficient with our electrical and water consumption continuously being reduced in the past 4 years. Upgrading our systems with new technology that allows for better efficiencies is and remains a focus for us.

We have started eliminating single use plastic in most areas of the hotel and guest room operation and will further expand this in 2021 to become single use plastic free by the end of the year.

What is the most crucial issue to tackle in the Hospitality industry today?

Identifying and developing talent for the growth of our unit business as well as building a talent base for the rapid expansion of Hyatt in India and across the region.

What do you enjoy most about being at the helm of affairs at the hotel?

We are not just providing a room to sleep, we are a multi-restaurant and bar operator, successful event space, spa, gym & pool operator with additional recreational facilities, which all require a different level of attention and approach, however all guided by Hyatt's purpose to care for people so they can be their best. This applies to guests as much as colleagues. I enjoy

dealing with so many different talented teams and individuals, who are all working towards the same goal in providing guests an exceptional stay experience.

What has been the most rewarding moment in your career?

As hoteliers we are often part of some of our guest's most important and intimate moments in their lives. This might be a proposal, a wedding, an important business meeting, a long awaited family vacation or any other very personal occasion. It is always so fulfilling to hear from guests how the team or a particular colleague was able to make a difference to people's experiences and their lives by providing them with genuine, personal attention that goes beyond expectations and the call of duty. This truly inspires me.

What is your working Mantra, your guiding philosophy in work?

I grew in my career, because my mentors gave me the freedom to be myself, experiment and fail at times. I follow the same principle with the people I work and believe in a guiding rather than managing approach.

One advise you would like to give youngsters aspiring to excel in Hospitality?

Behind the glamour, there is a lot of hard work. Especially the first couple of years will be challenging. Don't be afraid of it as the hospitality can be one of the most rewarding and fulfilling experiences in your life and open doors to many friendships, travel and professional growth.

www.cremica.com

Start a Party



Premium kettle crisps made with olive oil. Available in 8 exciting international flavours.

SALT & BLACK PEPPER
ITALIAN HERB

PIRI PIRI
ZESTY WASABI

SPICY BARBEQUE
FIERY SRIRACHA

CHEESE JALAPENO
TANGY CHIPOTLE

WE TAKE CARE OF YOUR DISHWASHING

Your Dishwashing Specialist.

Commercial dishwasher for perfect cleanliness & hygiene.



The new C50. A modular system for high capacity and hygiene

- Effective Filtration
- High Performance
- Saves Water
- User Friendly
- Saves Time
- High washing Capacity

Commercial Dishwasher Range:



Under Counter Dishwasher



Hood Type Dishwasher



Rack Conveyor Dishwasher



Multi-tank Rack Conveyor Dishwasher

Detergents Range:



PAN India Service Support & AMC Service
Toll Free Help Line No.
1800 1035 913*
(Mon to Fri, 9:30 AM to 5:30 PM,
Saturday, Sunday & Public holiday- Closed)

Head Office :
Winterhalter India Pvt Limited
Plot no 269, Sector 7, IMT Manesar - 122050, Haryana
www.winterhalter.in | email: info@winterhalter.in