

HAMMER

Food & Beverage

Feb-Mar 2021 • Volume XVIII Number 4 ₹ 100

Business Review

Business magazine for food service & food retail professionals

Women Cooking up a Storm?

Business

Maintaining Hygiene Amidst Pandemic

Feature

Revival for Restaurant Business

Agri

Red, Juicy and Cool

Processed Foods

Condiments are Crucial

Operations

Menu Planning

Profile • Restaurant • Chef Voice • Hygiene • Health & Safety



BONHEUR

SYRUP



*Presenting 130 years of
French Aromatic
Excellence*



FOR PRODUCT SAMPLE / DEMO PLEASE CONTACT

navin.kapoor@cremica.com, 8130131060

www.bonheursyrup.com

ORGANISER



INDIA TRADE PROMOTION ORGANISATION
(A Government of India Enterprise)

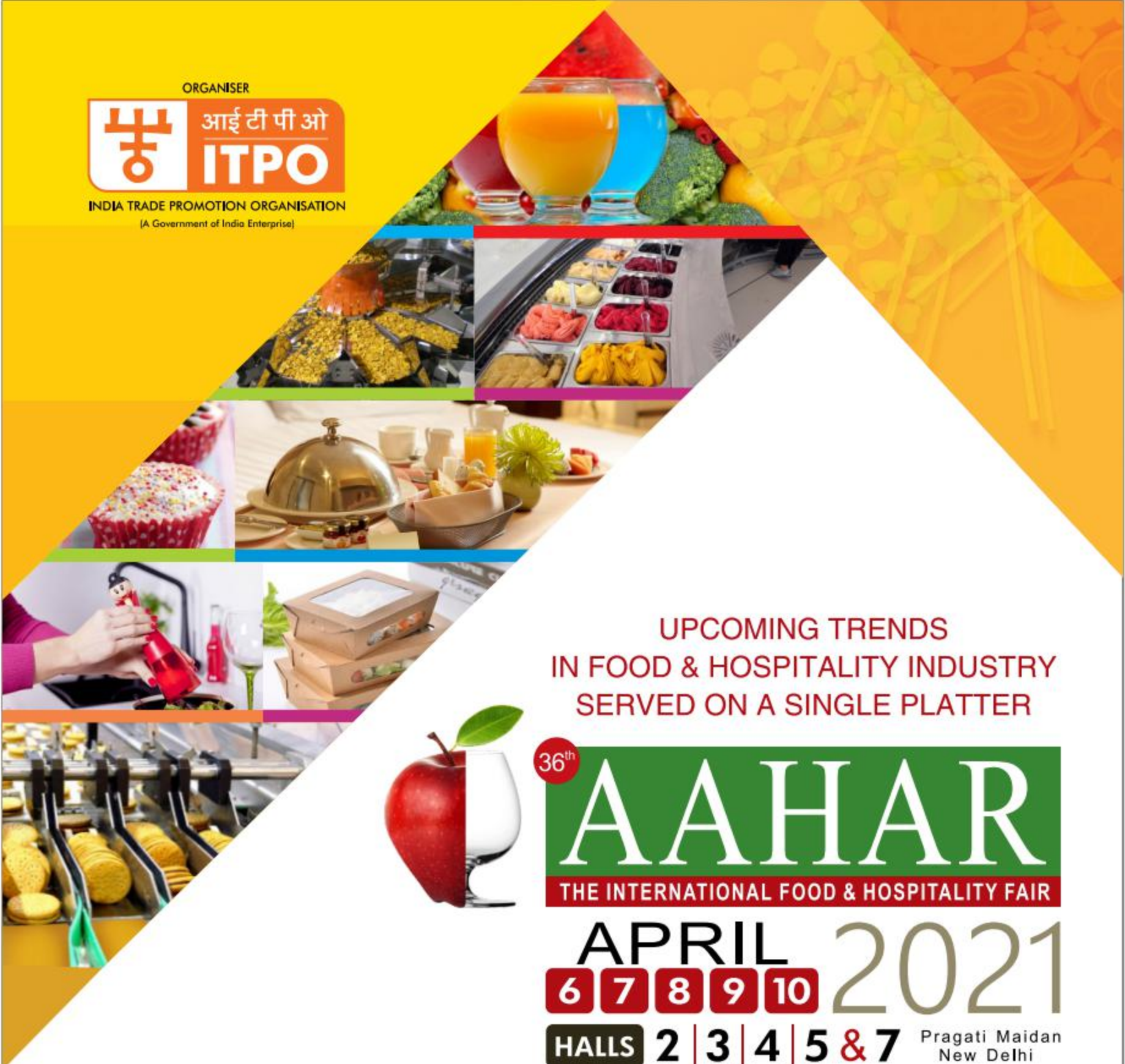

UPCOMING TRENDS
IN FOOD & HOSPITALITY INDUSTRY
SERVED ON A SINGLE PLATTER



36th
AAHAR
THE INTERNATIONAL FOOD & HOSPITALITY FAIR

APRIL 2021
6 | 7 | 8 | 9 | 10
HALLS 2 | 3 | 4 | 5 & 7 Pragati Maidan
New Delhi
(Ground & First Floor)

Follow us on

2, 3, 4 & 5 (Ground Floor)	F&B Equipment
2 (First Floor)	Food - Confectionery & Bakery Products
3, 4 & 5 (First Floor)	Food - Process, Beverages, Ingredient, Agri Produce etc.
7 (ABCDE)	Hospitality & Décor Solutions, Packaging and Startup Pavilion
7 (FGH)	Heavy Bakery Equipment, Hospitality & Decor Solutions
7 (Open Area)	Mist /Cooler/Food Truck/Decor

Supported by
Ministry of Food Processing Industries
(Govt. of India)

Agricultural & Processed Food Products
Export Development Authority (APEDA)

Associates



For Registration & Other Details please visit

Corporate Website: <http://www.indiatradefair.com> | Event Website: <https://www.indiatradefair.com/aahardelhi/>



Woman in India always excel in the kitchen at home but have not been able to make an impressionable dent in the male dominated kitchens of Indian hospitality industry. On this International Women's Day they must look forward to an equal future, a dominant position in the hospitality industry in India, particularly in the F&B segment. Cover Story examines the role, opportunities and prospects of female chefs in India.

In these unprecedented times people are most concerned about their health and are not sure whether it is safe to go out and dine in a restaurant. Business Story find out the steps being taken by the industry not only to maintain hygiene in the kitchens but also to keep the guests informed about these measures to gain their confidence.

Restaurant business in India is slowly recovering from the severe economic jolts it suffered due to successive lockdowns but it would still require some more time to reach pre-Covid levels of revenues and growth. The Feature Story discusses what routes majority of restaurants in India would prefer to take towards revenue and profit growth which require less investment.

The Operations section take a view of the industry experts on how curating a perfect menu is as significant as preparing a perfect dish and can help organize the food preparation not only to ensure good taste but also healthy and nutritious food.

Health & Safety section finds how food traceability helps in understanding the movement of a food product and its ingredients through all steps in the supply chain, both backward and forward. Also Hygiene section takes a look at the need of why Food Hygiene has become foremost priority post-covid.

Also read other regular sections for more information. ITPO has announced the dates for Aahar 2021. See details on the event page and plan your participation or visit to the show. You can contact industry associations like HOTREMAI or ARCHII for exhibiting at the show.

HAMMER
Food & Beverage
Business Review

Publisher cum Editor
Rajneesh Sharma
rajneeshhammer@gmail.com

Resident Editor
Sharmila Chand (Delhi)
Ashok Malkani (Mumbai)

Layout & Design
Hari Kumar V
Abhishek Singh Rathore

Production Assistant
Jyoti Gupta

Advertising Sales
Delhi: Debabrata Nath, Sumesh Sharma

Director Sales
Sanjay Anand
Mobile: +91 9811136837

Director Operations
Rajat Taneja
Mobile: +91 9810315463

Editorial & Advertising Offices:
Delhi:
Hammer Publishers Pvt. Ltd.
206, Samrat Bhawan, Ranjeet Nagar Commercial Complex,
New Delhi-110008
Phone: 91-11-45084903, 45093486, 25704103
Mumbai:
Hammer Publishers Pvt. Ltd.
105, 1st Floor, Aarpee Centre, Gufic Compound, 11th Road,
MIDC, Near Tunga Paradise,
Andheri (E), Mumbai-400093
Ph.: 022-28395833

Website: www.fbrmag.com
E-mail: info@hammer.co.in

© 2021 Hammer Publishers Pvt. Ltd. No part of the publication may be reproduced, stored in retrieval system, or transmitted in any form or by any means, electronic, mechanical, photocopying, recording or otherwise, without prior written permission of the publisher. Hammer Food & Beverage Business Review is a bi-monthly magazine, printed, edited, owned and published by Rajneesh Sharma from 302, Himgiri Apartments, J-Block, Vikaspuri, New Delhi. Printed at Print Creations, C-112/3, Naraina Industrial Area, Phase-1, New Delhi.

Editorial Policy: Editorial emphasis in Hammer Food & Beverage Business Review magazine is on educational & informational material specifically designed to assist those responsible for managing institutional food & beverage business. Articles are welcome and will be published on the sole discretion of the editor.

Disclaimer: The editor and publisher believes that all information contained in this publication are correct at the time of publishing. Content published not necessarily are the opinion or view of the editor and publisher. Editor and publisher declines any responsibility for any action taken based on the information contained in this publication, including liability for error or omission.

Annual subscription rate within India is Rs. 600 and for overseas it is US \$180, for surface mail. Single issue is available for Rs. 100 in India and US \$25 for overseas. Cheques are payable to Hammer Publishers Pvt. Ltd.

Contents

FEBRUARY-MARCH 2021



COVER STORY

18

Women Cooking up a Storm?

BUSINESS

26

Maintaining Hygiene Amidst Pandemic

FEATURE

32

Revival for Restaurant Business

AGRI

38

Red, Juicy and Cool

PROCESSED FOOD

40

Condiments are Crucial

OPERATIONS

44

Menu Planning

DEPARTMENTS

Event 04

News 06

Report 16

Profile 36

Chef Voice 42

Restaurant 48

Hygiene 50

Health & Safety 52

Product Preview 54

Interview 56



Cover Pic:
Louis-Hansel, Unsplash



AAHAR 2021

April 06-10, 2021, Pragati Maidan, New Delhi

ITPO has announced the fresh dates for Aahar 2021. It will now be held during April 06-10, 2021 in newly build halls 2, 3, 4 & 5 (Ground & 1st floor) of International Exhibition-cum-Convention Centre (IECC), Pragati Maidan, New Delhi.

The 36th edition of International of Food & Hospitality Fair – AAHAR 2021 will be a mega attraction for expert Chefs who persistently strive to make emerging India a food basket for world. Promoting “the Taste of India” globally, these masterful chefs are marrying old farming practices to biodiversity and modern techniques.

A five day flagship event of the India Trade Promotion Organization (ITPO), AAHAR2021 - is being offered with discounted rate of 45 per cent on participation charges, to support the industry. The fair will feature the emergence of India in F&B as well as hospitality services including food processing, culinary tech, retail and new innovations.

Significantly, AAHAR2021 is being organized in the halls of iconic International Exhibition-cum-Convention Centre (IECC) at Pragati Maidan, the display profile is segregated into four categories namely, Food Products, Ingredients & Additives, F&B Equipment, House Keeping & Engineering Equipment and Bakery & Confectionary.

It is expected that the large number of trade visitors will visit Aahar 2020.

Besides the potential to foster business revenues, Aahar also provides an effective platform for the players across global food & beverage and hospitality industry to disseminate/gather relevant information and gauge ongoing and future trends, which can greatly benefit the participants at the fair.

Apart from the meaningful display, the fair offers an insight to operational and food safety concerns and innovations to become energy-efficient, finding budget friendly raw materials boosting productivity, while still aiming for greater profitability.

The forthcoming mega event can be the right place for importers, overseas trade delegations and Indian players in the food & beverage and hospitality space, and also for policy makers and media personnel to exchange knowledge and information.

Going by the emerging and futuristic trends in the Indian food & beverage and hospitality industry, we can safely assume that the forthcoming edition of Aahar is expected to grace by impressive numbers of visitors.

In conversation with Rajesh Agrawal, Executive Director, ITPO

Aahar being the leading Food & Hospitality show in India, How are you going to ensure its success in these unprecedented times?

The 36th edition of AAHAR - the International Food and Hospitality Fair is a real manifestation of commitment of ITPO as well as incredible grit and resolve of the industry. In the present scenario, the success of this B2B event will be ensured through strict adherence by all stakeholders of the mandatory ‘SOP’ as per prevailing health protocol notified by the Government. Apart from providing meaningful media interface, ITPO has been working to provide conducive business environment for the event in the new halls of IECC at Pragati Maidan, New Delhi. The success of a fair primarily depends on the business visitors, trade discussions, enquiries and business networking. ITPO has taken a special initiative for AAHAR 2021 and is planning to host Buyer-Seller Meet completely funded by ITPO. We expect the buyer support programme will contribute to the visitorship to the event. Furthermore, keeping in view the challenges being faced by exhibitors in current COVID times, ITPO has gone ahead for significant reduction in rentals for AAHAR 2021 to support the Industry. We expect that with continuous efforts being made by the ITPO and with the support of all stakeholders, we will be able to together ensure the successful organisation of AAHAR 2021 in these difficult times.

How are you ensuring the proper representation by the industry in the form of exhibitors?

Significantly, AAHAR2021 is a collective effort of ITPO and its associates. Ensuring support of all verticals of food and hospitality industry, the event is being organized with support of the Ministry of Food Processing Industries (MFPI), Govt. of India and APEDA in association with apex trade bodies. These include: AIFPA, ARCHII, FAIC, FHSAI, FIWA, FIFA, HOTREMAI, FIFHI, KREMAG and ICMA.

How will you ensure visitors’ attendance at the show?

This year too, a large number of trade visitors are expected to visit the fair. These include top echelons of the hotel and hospitality industry including CEOs, General Managers, Executive Chefs, Executive House Keepers, Purchase Managers, F&B Managers etc, besides the senior representatives from Centre and State Government, catering industry and



academic.

In view to ensure a good footfall of visitors from all sectors of the industry, an integrated media plan has been implemented. Apart from online media interface, this includes focus on Industry publications, national dailies, FM, TV, outdoor and social media. Also the apex trade bodies are also making efforts to invite potential buyers from India and abroad.

Moreover, as mentioned earlier, we are hosting a buyer’s programme on the sidelines of AAHAR 2021 to supplement the visitorship during the event. We have also planned a culinary show on the sidelines of AAHAR 2021 to attract the relevant visitors especially the Chefs of the industry to this show.

What Covid SOP’s you will observe during the show?

All the visitors, participants and service providers have to strictly follow the Standard Operating Procedures (SOP) as per the guideline issued by the government for managing the Covid19 during the B2B event Aahar 2021. It is mandatory to register on Arogya Setu app. All persons must follow COVID appropriate behavior like maintaining a minimum distance of 6 feet in public, use of face covers/masks, frequent use of sanitizer, etc.

What major activities / events are planned during the show?

An exclusive ‘MICE Industry Unity Conclave’ will be held during the show. The event will be jointly organised by ITPO, on 9th April, in collaboration with the Exhibition Showcase magazine. The objective of conclave is to discuss issues being faced by the exhibition industry, especially ones which can be addressed collectively as a group. Furthermore, a number of exclusive seminars on the topics relevant to food and hospitality sector are also planned on all the days of exhibition. We expect industry will use this platform to debate and discuss the challenges before the industry and new opportunities COVID pandemic has opened for the sector.



THE WORLD
OF
CHEESE

ON YOUR TABLE



BROUGHT TO YOU
BY

gnosch
GNOSCH FOODS PRIVATE LIMITED
foods of the world

Electrolux PROFESSIONAL
Genuine Spare Parts

	
MAIN BOARD HOOD TYPE DISHWASHER	HEATING ELEMENT HOOD TYPE DISHWASHER
	
RELAY HOOD TYPE DISHWASHER	JUNCTION BOX HOOD TYPE DISHWASHER
	
PUMP HOOD TYPE DISHWASHER	RFI FILTER HOOD TYPE DISHWASHER
	
SPRING CONVEYOR DISHWASHER	WASH PUMP CONVEYOR DISHWASHER

ACCESSORIES

Authorized Distributors

Sterling Solutions
 A COMPLETE COMMERCIAL KITCHEN SOLUTION

Mob. +91-9654025492, 9582956269
 E-mail : sterlingol@outlook.com
 Website : www.sterlingsolutions.in

Empress of China's Reopens

Eros Hotel New Delhi Nehru Place announces the reopening of "Empress of China" which is known for its authentic Chinese flavours and old world charm. The fine dining Chinese speciality restaurant boasts of an elegant and spacious private dining room with attached lawn that provides a stunning view of the



famous Lotus Temple and also makes guests close to the nature. Empress of China epitomes the magic of authentic Chinese delicacies and brings out distinctive and contrasting flavours of the three main provinces namely – Sichuan, Yunnan and Hunan.

Master Chef Tenzin Losel along with his team has curated a gourmet menu offering ample options for all food connoisseurs. Empress of China's specialities include Beijing Duck, Szechuan Red Snapper, Salt Baked Chicken, Empress Dim Sum Platter, Empress Corn Cake, Steamed Jasmine Chocolate among others.

According to Davinder Juj, General Manager, "In light of the current situation, we are following all protocols to keep the place hygienically clean and safe for all our guests and team members. We are taking all safety precautions and ensuring safe distancing so that our patrons feel the same warmth and comfort while enjoying their favourite food at Eros Hotel".

BL Agro Launches New Exclusive Brand Outlet

BL Agro Limited, India's leading FMCG Company, launched its 12th Exclusive Brand Outlet (EBO) 'Nourish'. This is the company's first outlet in Delhi, located at Janpath Bhawan, a prime location in central Delhi, the store was inaugurated by famous Bollywood singer Kailash Kher.. The Nourish store will retail a wide range of 80+ products that the company offers. The company is amongst the fastest growing FMCG brands in the country and has been committed to providing quality food products over many years.



Commenting on the launch, Ghanshyam Khandelwal, Chairman & Managing Director, BL Agro Limited said, "Since the launch of our first Nourish store in Padrauna, our experience has been nothing short of extraordinary. We are humbled by the response we have received till date, and our passion towards providing an ever-growing nation with the right nutrition, is what sets us apart. We are excited for our customers to experience our brand this way and hope we can help people understand the importance of choosing the right nutrition."

Brand Nourish came into existence in the year 2018 and comes with a promise for nutrition. The brand offers an entire range of food products typically used in an Indian kitchen including Atta, Rice, Pulses, Ghee & Oils, Dry Fruits, Papad, Pickles, Murabba, Spices, and more. Each Nourish product is packed with superior quality ingredients and is produced with finest processes that ensure maximum retention of nutrients.

Vegetable Washer



Tilting

Non Tilting

The traditional way of washing fruit, vegetable, meat, fish and frozen food is both time consuming and usually does not guarantee the removal of all unwanted insects and dirt. The problem of washing large quantities without damaging the structure and quality of vegetables and fruits is easily solved with our vegetable washer. This machine is designed to aid removal of dirt, wax and pesticides from the fruits and vegetables before they are enter your kitchen.

Jewel Case Display Cabinet

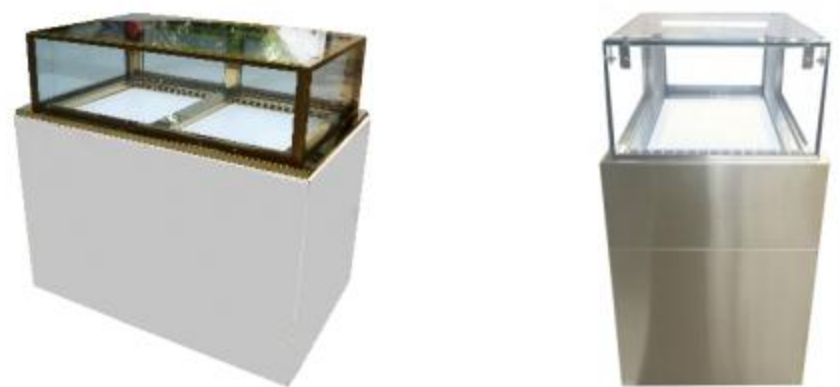

2 Drawer Cabinet (Drop-In)

1 Drawer Cabinet

RANS present its latest range of elegant front of the house jewel case display cabinets. Available in both free standing and drop-in models. Jewel cases can be customised in numerous colors of designer stainless steel to match the interior color theme. A must have for all upmarket bakery and confectionary stores.

Pizza Oven



Stone Hearth Ovens

Stone Hearth Ovens

Designed to bake and roast a wide variety of food, they are built to last and are capable of continuous duty 24 hours a day. This together with their user-friendliness and very smart appearance, makes them the ideal solution for restaurants and front-of-shop applications where safe, efficient, unobtrusive equipment is needed.

Salamander



Brownie

Box

RANS salamander grills are known and used by the kitchen chefs all around India. Equipped with specially designed tubular air heater it assures perfect cooking results. Our salamanders are equipped with two cooking areas - both can be used independently from each other. With the RANS salamander grills you can grill, cook "au gratin", glaze, caramelize and make crispy food in no time. It is reliable, flexible and easy to use.

Holding Cabinet



Cold Food Holding Cabinet

Hot Food Holding Cabinet

Our durable holding and transport food cabinets are constructed in full stainless steel body with best of the features your restaurant and commercial operations may require. Our hot holding cabinets ensure food remains hot and safe for upto 4 hours without losing its moisture. Ideal for banquets, restaurants, coffee shops and cloud kitchens.

Bulk Steamer



Electric / Gas Operated Models

Commercial steamers are designed for new generation of kitchens. They are simple to use, having complete robust S.S construction and energy efficient. They are designed for schools, factory, hotel, banquet kitchens and restaurant. Ideal for steaming rice, vegetables, Idly, fish etc.

RANS TECHNOCRATS (INDIA) PVT. LTD.

An ISO 9001 : 2008 Company

201, Samrat Bhawan, Ranjeet Nagar Commercial Complex, New Delhi-110008

Ph.: +91-11 45189999 (30 Lines) Fax: +91-11 45189911 E-mail: info@ransindia.com, Website: www.ransindia.com

Factory: Plot 159, Sector 6, IMT Manesar, Gurgaon, Haryana-122050 Ph.: 0124-2290060

Alto-Shaam Expands Presence in India with New Chef



Alto-Shaam, a recognized leader and innovator in the global foodservice equipment industry, has added Shailendra Kekade to be a chef ambassador for the India market. As the first representative chef ambassador in the region, Shailendra will provide insight and support to customers while promoting and demonstrating the capabilities of Alto-Shaam's complete range of kitchen equipment solutions.

With more than 25 years of culinary experience in a variety of bakeries, cafes and restaurants across the US, Europe and India, Shailendra has built a reputation as an authority in the restaurant industry. Shailendra has also worked as a restaurateur, TV personality, concept visualizer and designer.

Shailendra will work with Vijay Kisanrao Pawar, Alto-Shaam's Regional Director of Sales and Culinary for India and Sri Lanka. Vijay says he is very excited to add Shailendra to the team: "His many years of experience working as a chef across different continents and multiple cuisines, as well as his proven culinary skills and intricate knowledge of ingredients, will make him a pivotal addition for Alto-Shaam. I look forward to working closely with him."

Burger Singh Launches Vegetarian Outlet

Burger Singh, the leading chain of Indianised fusion burgers, has launched its first Vegetarian only outlet in Ahmedabad. By 2022, the company aims to have over 45 outlets in Ahmedabad, Surat, Vadodara and Rajkot. Burger Singh's Indian taste and flavours make it stand out from the other burger brands in the QSR category. In Gujarat, the burger chain has gone one step further and has introduced new vegetarian burgers influenced by the predominantly vegetarian local cuisine to cater to the local palate.

"Gujarat is a phenomenal market on account of the tremendous love for food. To add to the excellent street food options available in the state, we are bringing our wide range of vegetarian burgers, curated especially to match the vibrant flavours of Gujarat," said Kabir Jeet Singh, CEO and Co-founder, Burger Singh on the launch.

Burger Singh has capitalised on the unique Indian palate and has catapulted to new heights by fusing Indian flavours into western



burgers and is also renowned for its vegetarian range of products. Presently 60% of all Burger Singh sales countrywide come from their vegetarian offerings. The Veg menu includes a wide variety of Burger ranges - Potato Crunch, Uda Punjab 2.0, Crispy Paneer Bhurji, Veg Keema, and many more.

Currently, the burger chain has 35+ outlets across India with other 26 franchises under fit-outs across the country in cities like Lucknow, Jaipur, Nagpur, Hyderabad, Surat, Delhi NCR, and Chandigarh. The brand also has established an international presence with three outlets and one food truck in London. The respective franchise partner of Burger Singh has plans to take this number up to 17 in the next three years.

Sayaji Pune Launches 'The Pearl'

Sayaji Hotel Pune has launched an all-new premium banquet place for wedding and corporate events, with the commencement of 'The Pearl'. The Pearl offers a rare combination of high-quality, elite and exclusive experience under one roof and promises to provide grandeur for all offered customized services that will redefine the standards of celebration.

This luxury banquet is one of the most prime spaces in the area. It can house up to 150-200 guests at a time and almost 320 guests in theatre-style seating arrangement. It is spread over 2,000 square feet of carpet area and has an outside pre-function area of 800 sq. ft.

Sayaji Pune introduced its lavish event space over a gala



affair. The event was filled with exciting events and performances and was attended by a lot of noted personalities from the town.

Celebrating
56 years
of handcrafted excellence



MUNNILAL
— T A N D O O R S —
★ ★ P R E M I U M ★ ★



Visit us at AAHAR 2021 for our
Tandoori Chai Cart

Tea Tasting Experience with
Earthy Flavours & Aromas



5 decades of
hand crafted
excellence.

MUNNILAL
— T A N D O O R S —
PRIDE
DEALERSHIP APPLICATION INVITED



CLAY TANDOOR | COPPER HAMMERED TANDOOR | COPPER MIRROR FINISHED TANDOOR | STAINLESS STEEL ROUND TANDOOR | STAINLESS STEEL SQUARE TANDOOR
MILD STEEL ROUND TANDOOR | MILD STEEL SQUARE TANDOOR | WOOD FIRED OVEN | HOME TANDOOR | SIGRI

Munnilal Tandoors Pvt. Ltd.

All tandoors are available in various shapes and sizes. They can also be customised as per requirement.

Registered Office:
Pocket H-19, H.No, 139, Sector - 7, Rohini, New Delhi- 110085,
Mob: +91 98103 63638, +91 98113 63638

Manufacturing Unit:
C-7, Swami Sharda Nand Park, Near Bhalaswa Dairy, Opp, Sanjay Gandhi
Transport Nagar, New Delhi- 110042, Ph: 011-27812306, 011-27812435,



Please scan the
QR code to
visit our website

CALL CUSTOMER CARE:
927 TANDOOR
8263667

e-mail: sales@munnilaltandoors.com, website: www.munnilaltandoors.com

Blisswater Launches Rahasya

Blisswater Industries Pvt. Ltd. has introduced Rahasya – craft Vodka inspired by the mysticism, heritage, and folklore of India. Rahasya marries India’s heritage with its new, self-confident



future. Currently available exclusively in Goa where it is produced, it will soon be available in other parts of India as well.

Rahasya is the brainchild of Varna Bhat, a first-generation entrepreneur who comes from a creative industry background of branding, events and experiential marketing. “The intention was to create a product from India for the world with pride in India’s rich and glorious civilizational brilliance” says Varna.

She further added, “Rahasya has been launched keeping in mind the growing popularity of white spirits in India. Conceived with the objective to create a product that represents India and with a lot of careful research on India’s ancient traditions, we created this unique blend.”

The company’s vision is to take the taste of India to the world. The product is targeted at the new age consumer who is aspirational and well-travelled yet strongly rooted to the ethos of India. By the end of 2021, Rahasya will be available across Karnataka, Chhattisgarh, Maharashtra and other states the country. Blisswater also plans to make the vodka available overseas as early as mid-2021.

‘Mrs. Bector’s Cremica’ Founder Rajni Bector Gets Padma Shri Award

Mrs. Rajni Bector, who started ‘Mrs Bector’s Cremica’ food brand, was awarded prestigious Padma Shri award by President Ram Nath Kovind. The Padma Shri is amongst one of the highest civilian honour of the country. She on receiving the award said, “I had never expected that such a big honour would be conferred upon me. I never even dreamt of it. I was extremely happy after getting the news of my nomination. I am really very thankful to the Government of India for selecting me for this honour”.



Mrs. Bector started the food business around 43 years ago at Ludhiana in Punjab. She was fond of cooking and use to invite family and friends at home to experience her passion. People started encouraging her to step into the business and soon after, this idea received support from her husband Late Dharamvir Bector and father-in-law Late Lakshman Das, prompting her to convert hobby into profession.

Starting with an ice cream stall at a fair, she became an entrepreneur by starting in 1978 an ice cream business from home, which was further expanded to puddings, cakes and breads. Later she established ‘Mrs Bectors Food Specialities’ selling various products under the initial brand name. As of now, her company operates ‘Cremica Foods’, ‘Mrs Bector’s Cremica’ and ‘English Oven’, brands manufacturing biscuits, bread, and ice cream along with condiments, sauces, spreads, syrups, jams, opera chips etc. Her two sons, Anoop Bector and Akshay Bector are currently running different divisions of the company.



CHANDRA ENGINEERS
Commercial Kitchen & Laundry Equipment
OEM/Replacement Parts, Repair & Maintenance

*One Stop Solution for
Commercial Kitchen and Laundry*

Kitchen Range



Laundry Range



Best of International Brands for Complete Range of Commercial Kitchen, Catering Equipment, Commercial Laundry & Dry Cleaning Equipment

**Spare Parts for
Commercial Kitchen and
Laundry Equipment**



**Repair & Maintenance for
Commercial Kitchen
and Laundry Equipment**

CHANDRA ENGINEERS
Khasra No. 173, Ground Floor, Behind SBI Bank, Rithala, New Delhi- 110085
INDIA, Tel.: +91-11-27042121, Mobile: 9811622587, 9811625827,
9811437558, 9990058517, Email : info@chandraengineers.co.in,
chandra.ce@gmail.com, Web: www.chandraengineers.co.in

Oakwood Launches Ozaa

Oakwood Premier Prestige Bangalore launched Ozaa, a rooftop poolside restaurant specialising in Mediterranean Grills. The restaurant with a stunning view of the city’s gorgeous skyline with Cubbon Park and the glorious Vidhana Soudha showcases a harmonious blend of Lebanese, Jordanian, Moroccan, Greek, Syrian and other Mediterranean cuisines.



The brand-new restaurant with live grills offers a selection of dishes such as Lamb Arayes, Muhammara, Prawns in traditional Emirati spices, the popular Adana Kebab, Samke Harra, Kanafeh, and much more but the piece de resistance is the Spiced Moroccan Stew made using slow cooking technique in a Tagine.

On the occasion of the launch of the much-awaited outlet, the GM Wajeed Bagwan said, “We have been working to perfect this grill and diner for the last year and half with the aim of bringing to the people a fun and authentic experience of the Mediterranean cuisine. The ingredients in the menu have all been sourced from various parts of the country and the world they are best known for.”



You make it happen

INNOVATIVE IDEAS. INVEST IN THE FUTURE



KORE GENERATION: ROBUST DESIGN AND AN IMPECCABLE LEVEL OF CLEANLINESS



FROM ONE PROFESSIONAL TO ANOTHER

COMBI OVEN



VISIT US @ AAHAR 2021 Hall No. 4 Stall No. 10A

Fagor Industrial S. Coop.

Santxolopetegi auzoa, 22
20560 Oñati, Gipuzkoa (España)

T. (+34) 943 71 80 30
F. (+34) 943 71 81 81

info@fagorindustrial.com
www.fagorindustrial.com

F-89/8, 1st & 2nd Floor, Okhla Industrial Area Phase-1, New Delhi 110020 (India) T. +91 1140 649 001 M. +91 9313433186 Email: h.bist@fagorindustrial.com

Foodservice India Acquires SIL



A VKL Food Solutions Enterprise



A VKL Food Solutions Enterprise

The investments in food industry are on the roll again. Sil Foods Pvt. Ltd., one of India's oldest and trusted food company has been acquired by Foodservice India Pvt. Ltd., a leading food solutions company for the Food service sector in India and Middle East, for an undisclosed amount.

With this acquisition, SIL will get the resources to expand its distribution footprint as well as product range. SIL has a presence in Indian market for over 70 years and has a product range which includes Jam, Sauces, Ketchup, Canned products and Mayonnaise in their retail product portfolio. It is one of the brands which have been in the country ahead of its time in launching the niche products like baked beans,

mayonnaise in the country.

The company is known for unique products which are made using the traditional processes combined with modern technology. The Soya sauce manufactured by the company is made with



the traditional fermentation process. The company manufactured all its products in a factory near Pune, Maharashtra.

Food Service India has established

itself as a leading food solutions provider with a strong market presence in the hotels, restaurants and catering segment with multiple product categories like seasonings, spices, gravies & sauces, beverage solutions, etc. Foodservice India Pvt. Ltd. solutions are used by over 25,000 Restaurants across Indian Subcontinent and Middle East. The company is present in over 70 cities across India.

Foodservice India Pvt. Ltd. is a part of VKL Food Solutions Enterprise which is India's leading food solutions group, which established VKL seasoning Pvt. Ltd., a company where Firmenich, one of the world's largest ingredients and flavours company, has recently invested.

'Quilon' Retains Michelin Star

Located in the heart of London at the iconic Taj 51 Buckingham Gate Suites and Residences, London, Taj's prestigious Indian restaurant, Quilon, has been awarded a Michelin star for the fourteenth successive year in the Michelin Guide for restaurants in 2021. First awarded a Michelin star in 2008



and consistently retaining it ever since.

Quilon prides itself on South-west coastal Indian cuisine as evidenced by signature dishes such as Black Cod and Coconut with Asparagus and Snow peas or Lobster Butter Pepper. Known for its progressive interpretation of ethnic cuisine, the restaurant showcases the region's culinary diversity and blends old traditions with modern tastes. Quilon's experience is one of a kind in the city of London and Chef Sriram, has been leading the restaurant successfully ever since it opened its doors.

Digvijay Singh, General Manager, St. James' Court & Taj 51 Buckingham Gate, Suites & Residences, London said, "Quilon since its opening in 1999 has set new trends and benchmarks in recreating and presenting India's South West coastal cuisine with a modern twist. The restaurant has constantly reinvented itself to offer differentiated dining experiences in London's culinary landscape. Congratulations to Chef Sriram and the talented team of Quilon for retaining a Michelin Star for the 14th consecutive year."

Bira 91 Promoting a Beer First Culture

Bira 91, one of the fastest growing beer brands, with its portfolio of flavourful beers is instilling a beer first culture within the organisation. The sales and marketing team at Bira 91 enrolled to participate in the Cicerone Certification Program, that is a series of four professional certification exams starting with the Certified Beer Server and ending with the top-level Master Cicerone.



With roots in the North American craft beer movement and in-depth coverage of classic European beer culture, the Cicerone program has become the global standard for assessing beer professionals since its launch in 2008. Bira 91's Cicerone Certification program was designed in the summer of 2020 when teams were working remotely - it was not only designed to help build education on beer flavour, service and style, but also help the team connect the learnings to the beers in Bira 91's portfolio.

Speaking of this, Ankur Jain, Founder & CEO, said, "We are building a beer-first culture at our company. The first step towards that is to ensure that we develop our sales team to be the most knowledgeable team around different beer styles, beer making and beer service. I am excited to see our team take the lead and use the downtime in Covid-19 to upgrade their skills. It is a great demonstration of our passion for beer and our role as evangelists for the gospel of good beer in the country."

"Bira 91 is taking the lead in quality beer service through their education initiative with the Cicerone program," said Ray Daniels, Founder & Director of the Cicerone Certification Program. "As a result of their efforts, their staff will be prepared to provide all customers with an informative and enjoyable experience. They are the first organisation in SE Asia to be taking up a full and thorough implementation of the program".



Bulk dishwashing solutions for total peace of mind
COMMERCIAL DISHWASHING SOLUTIONS



SMART
SAVE

- Impeccable hygiene
- Water savings
- Manpower savings
- Quick turnaround
- Virtually zero breakages



Commercial Laundry range



Commercial Dishwashing range



24x7 Service across India



Commercial essentials



The Culinarial Convocation

The Cook and Bake Academy held their convention to conferred Graduates in a grand ceremony. The academy is a decade old in the profession and is credited with nurturing many budding culinaries into world class professional chefs. Known for imparting skills by providing hands-on training from the experienced faculty the academy has set a mark in the field of providing Diploma Certification in Culinary Arts & in Bakery Patisserie for the young aspirants.

The event was graced with the presence of distinguished & acclaimed hoteliers, professionals from the F&B industry, sponsored by leading brands. The event opened with facilitation of Chief Guest - Chef Vivek Saggar, General Secretary, Indian Culinary Forum, and a warm welcome speech for all the invitees, followed by awarding Diploma Certification to students along with Sponsor's gift hampers. The guests were honoured with Certificate of Appreciation. Hi Tea for students and a lavish spread for the sponsors and invitees.

While addressing the students Chef Vivek Saggar, General Secretary, Indian Culinary Forum emphasized saying "The Cook and Bake Academy has been working rigorously on improving skills of aspiring students and is on the path of creating valuable education & skill-set for the coming times", reinstating



the very purpose of the esteemed Academy.

The Graduation day was a grand affair and provided a variegated platform for students to exchange thoughts & their experiences with the academy in the presence of renowned chefs and in-turn were given feedback & suggestions by the experts, to enable them to improve their skills & presentation all the more. The event even helped the new chefs in networking with the industry experts opening up avenues far and wide.

Cook and Bake Academy was established by Chef Nitin Pal Singh and Chef Manoj Pawar. Chef Nitin Pal being a connoisseur himself and a master professional in Oriental and

Continental Cuisine, having more than 20 years of experience in Culinary preparation, restaurant planning, evolved his dream of creating a well-trained professionally equipped talent pool for the Hotel Industry, providing the young Chefs a promising future. The Academy has successfully placed students in Indian & Foreign Hotel Industry, further aspiring to fulfil the dreams of many more attached to the Cook and Bake Family.

The list of invitees includes Chef Sireesh Saxena, Chef Ajay Sood, Chef Arvind Rai, Chef Bharat Alagh, Chef Sudhir Arora, Chef Vinod Kumar, Chef Anirudh Sethi, Chef Sanjay Thakur, Chef Kapil Sahi, Chef Shailendra Singh, Sanjay Anand, Gurpreet Singh Tikku, Puneet Chhabra, Rakesh Arora, Ms Aradhika Singh.

List of Sponsors includes Cornitos, Amul, Catch Spices, Spichi, Miraya International, Deli Delicacies, The Gourmet Experience, Drapes by Arora, Horeca Magnets, Hammer Publishers, World Chef Choice Association.

Grover Zampa Vineyards Launches Riesling Wine

Grover Zampa Vineyards adds another feather to their Art Collection range with the launch of Riesling wines. Grover Zampa's Art Collection range takes winemaking a notch higher by treating it like a piece of beautiful art. As a tribute to some of the most reputed Indian artists, it takes inspiration from their work. The entire collection is curated in the brand's aesthetic style with vision and inventiveness. There are 8 varietals within this range allowing patrons to delve into versatile styles within one brand.

Speaking on the launch, Vivek Chandramohan, Chief Executive Officer says, Art Collection Riesling is the

second new release this year to our most awarded Art Collection range. We are among the few wineries that make wine with Riesling which is a grape variety most popular from Germany. The winemaker and viticulturist team has done a fabulous job to produce a wine of fine quality given that Riesling is a cool climate and delicate grape variety by ensuring to maintain the varietal characteristics of the grape variety complemented by aromas and flavours of Indian terroir."

The Art Collection Riesling is pale yellow with a bright green tint. It is accentuated with fruity and floral

notes of peach, pear, and lime blossoms. It is further complemented with flinty mineral notes. An evolved Riesling showcases aromas of beeswax and kerosene. Dry in style with a very refreshing acidity supported with tropical fruit flavours provide a perfect mellow mouthfeel. It is fermented and aged in concrete tanks. Served chilled at 8 - 10°C, it pairs well with Asian and Indian preparations, seafood such as basa fish, oysters, poultry, and vegetables like eggplants, carrots, bell peppers, and tomato-based dishes. It also goes well with flavoured soft cow's milk cheese and dried fruit.





Your One Stop Solution

Planning, Procurement,
Erection & Commissioning Of
Complete Commercial
Kitchen & Catering Equipment

Complete
Range of
Kitchen &
Catering
Equipment
Custom Built
in India



Water/Milk Boiler



Refrigerated Display
Cabinet



Idly Steamer



Four Burner
Range



Sandwich Griller



Hot Plate



Breakfast
Trolley

Certified Dealer



BLUE STAR

MOD KITCHEN EQUIPMENT PVT. LTD.

3A, Street No.4, Block No. RZ, Anand Parbat Industrial Area, New Delhi-110005

Tel.: 91-11-28763958, 28762343 Mobile.: +91 9811085683

Fax: 91-11- 28762342 Email: modequipment@yahoo.co.uk

Website: www.modequipment.com

Imported Equipment Marketed in India



Cutlery Dryer



Food & Service Equipment
Chinese Wok Range



Electric Dough Sheeters



Spar Mixer



Refrigeration Equipment



Glass & Dishwashers



Induction Hobs & Woks



Hi-Light Infrared Cooker



Bakery Oven



Salamander



Meat Mincer



Plate Warmer



Display Sushi Case

Other Overseas Partners



Third Culture Introduces New Range of Beverages

Third Culture, a US-based beverage brand is now extending its reach to the Indian shores and it is starting off with all natural low-sugar coffee cold brews and healthy carbonated beverages. Third Culture, a popular brand in Seattle, is ready to serve its delicious, all natural, healthy options to the woke Indian consumers, who aren't fans of the sugar-loaded drinks already available in the market and are demanding better options.

Third Culture is built on the pillars of Health, Diversity & Sustainability. The company believes in sourcing the highest quality local ingredients, supporting local farmers and crafting beverages with precision and time to develop delicious flavour. Their proprietary recipes and processes have been developed over the years with their international expertise and sets their offerings apart in taste and quality from all other beverages in the market.

Third Culture is a clean label product – with everyday ingredients that everyone understands, without all the harmful artificial ingredients. Each beverage is founded on a primary everyday superfood whether it is Coffee, Ginger or Turmeric –craft-brewed over 3 days in small batches to develop delicious flavour. The drinks have absolutely no preservatives, no concentrates, no additives, no high fructose corn syrup, and most importantly, no chemicals.

Third Culture beverages are available for purchase through their website drinkthirdculture.com for local delivery across NCR and in February will be available for national delivery across India through their website and soon through Amazon. They are selectively working with premium retail chains throughout the country and will be kick-starting their launch with Godrej's Nature Basket in Mumbai.

When asked about the thought behind Third Culture, Co-founder & CEO Radhikka

Kapur said, "Third Culture was built on the aim of bringing people together by celebrating cultures across the world through the medium of cultural healthy beverages. A Third Culture person is one whose home is defined by people and emotions that connect them with people rather than geographies, a person who absorbs and integrates the best of culture's they are exposed to, for a more holistic and fulfilling lifestyle."

Talking specifically about the launch, she pointed out "More than a launch, this is more of a homecoming for the brand because India is perhaps one of the best examples of diversity in the world, where all cultures are celebrated. We are excited to



showcase the best of international beverage styles that we have a well-established reputation for, to the discerning Indian audience. The trends in India are changing, aligning more and more to international trends, where audiences are demanding healthier products, with high quality ingredients that align with the values that are important to them. By implementing our hyper local strategy, we are excited to showcase the high-quality local ingredients and the amazing beverages that they can produce. We are humbled and excited to be part of "Made in India" by bringing the best of our experiences and crafting them

in India for Indian consumption".

About stepping into the Indian market, Co-founder Sandeep Kini said, "We have always focussed on building our connection with the consumers directly to showcase our delicious, healthy, high-quality product. It is a relationship based on trust which we always prioritize above anything else. The product rollouts for India and US are aligned and we are excited about bringing the best of cultures around the world to both the markets. Our global launch truly defines Third Culture and enables us to be a leader in the movement of providing healthier everyday options that are good for us. By focusing on an e-commerce platform and offering subscription programs, we are building direct connections to the consumer."

With sustainability as the company's third pillar, Third Culture is conscious of each and every choice they make and how it impacts the environment. From choosing recycled glass for their bottles, to committing to a "no plastic" rule, to using recycled paper for packaging, Third Culture is committed to do better every day. With continued support from the consumers, they hope to continue building on that initiative as the company grows.

Third Culture has already made a name for their globally-inclusive vision when it comes to coffee, tea, and healthy beverages. Coming from the coffee and craft brewing capital of the world, Seattle USA, Third Culture finds joy in crafting beverages that are delicious, local, nutritious and contribute to creating healthier lifestyle options with absolutely no compromises on taste or quality.

Run by a lean team that is high on passion and energy with a mission to make the world a more healthier and inclusive place, Third Culture celebrates the inherent goodness of everyday super foods, providing options that will become the new essentials & favourite of the entire family.

Experience Luxury

THAT TRANSCENDS BEYOND WALLS



BRAID & ROPE FURNITURE



WICKER HANDWOVEN FURNITURE



TEAK WOOD & METAL FURNITURE

Loom Crafts India's Finest Range of All Weather Outdoor Furniture

EXCLUSIVE RANGE OF

DINING, SITTING & BAR STOOLS • SOFAS & RECLINERS • SUN-LOUNGERS • OUTDOOR ACCESSORIES



10 YEAR WARRANTY*



UV STABILIZED
RESISTANT TO ADVERSE
WEATHER CONDITIONS



EASY CARE
STAIN-FREE ZERO
MAINTENANCE





GUARANTEED
AFTER SALES SERVICE
ACROSS INDIA*



ENVIRONMENT
FRIENDLY RECYCLABLE
PRODUCTS

Head Office & Manufacturing Unit:

A - 7/98 & 99 South Side G.T. Road Industrial Area, Ghaziabad - 201009, UP, India. • Contact: 8448440556 • Follow us at  

DELHI • LUCKNOW • BENGALURU • CHENNAI • BHUBANESWAR • HYDERABAD

For more information & detailed catalogues visit www.loomcrafts.com or e-mail us at info@loomcrafts.com

Women Cooking up a Storm?

The term 'Women in kitchen' is attaining new meaning today. From women in the kitchens at home to women chefs in the F&B outlets in hospitality industry they have steadfastly, despite several handicaps, made a solid and sturdy progress. The result is that today women in India are ruling the roost in several F&B kitchens. But the ratio to male chefs is still negligible as compared to the U.S. where, according to the National Restaurant Association, over 60% of American women have worked in the restaurant industry at some point in their life. As women entrepreneurs and achievers break glass ceilings in every field in India, **Ashok Malkani** raises a toast, on this International Women's Day, to those who have carved a name for themselves in the hospitality industry – particularly in the F&B segment – and examines the role, opportunities and prospects of female chefs in India.

While a woman is considered to be the kitchen queen at home she seems to have not yet been able to make an impressionable dent in the male dominated kitchens of the F&B segment of hospitality industry. As the world celebrates International Women's Day it is a sad commentary that while women have carved a niche for themselves in several industries they have yet to acquire a dominant position in the hospitality industry in India, particularly the F&B segment which is supposed to be their forte. The UN Theme for International Women's day 2021 is "Women in Leadership: Achieving an equal

Speaking about women and employment, in general, it may be mentioned that though women account for over 58% of the world population, less than 30% occupy top executive positions in various fields. Only 21.7% of enterprises, all over the globe, reported that their CEO was a woman. According to Global Entrepreneurship Monitor (a research consortium dedicated to understanding the relationship between entrepreneurship and national economic development) the Total Entrepreneurial Activity (TEA) for women, globally, is 10.2%, about three-quarters of that seen for men.

According to Ksanita Seruvatu (former Director of Training in the Fijian ... Gender

way I approach my daily operations. As a woman, a strong mindset and a desire to utilize the strength in skill, knowledge and experience keeps me motivated. With both men and the women bringing different skill-sets to the table, it only paves way for diversity at the workplace."

She adds, "Wearing many hats is often a regular occurrence in a woman's life; what with balancing careers, households among other things. However," she admits, "the trend and culture in our industry is changing drastically, and many more females are being empowered to come forward and make a mark. I truly believe women make phenomenal leaders because they are experts at making the impossible



future in a COVID-19 world". While women empowerment might be prevalent in a few industries it seems to have been negligible in the hospitality sector.

There are, of course a few women like the late Tarla Dalal, who had bagged a number of awards for her expert culinary skills. Her over 100 cookbooks have kept her world famous recipes alive and are cooked extensively in Indian homes.

Women have to aggressively push forward to gain a status in the F&B industry. To close the gender gap in the F&B kitchens, between the male and female chefs, today's women have to take the reins and be the torchbearers.

Equality at the Heart of Decent Work Campaign 2008-09), there is a patriarchal attitude towards women in the world of work and sometimes women are given token positions to pacify the strong advocates in women issues and to more or less 'keep their mouths shut'.

Women definitely have to struggle hard to find a rightful place particularly in the hospitality industry and the F&B sector.

Take the case of Ashika D'Souza, Assistant F&B Manager, ITC Windsor, Bengaluru. She says, she has succeeded because "My passion for hospitality and relentless curiosity for the profession enabled me to constantly innovate the

seem possible. And sometimes on a good day they even make it look effortless. "

There can be no doubt that women have to constantly prove their mettle. This is all the more prominent in the F&B segment.

There are several reasons that F&B professionals attribute for preference of males in the kitchens.

As Neeraj Rawoot, Executive Chef – Sofitel Mumbai BKC explains, "Even in today's day and age, we still all expect women to take care of the home, bring up children and cook for the family. So, in my opinion, for a working woman it becomes slightly challenging to balance her work

and personal life. It becomes even more difficult if your work demands long hours. A professional kitchen is one such place, where you have a substantial commitment on time and energy, because you cater to five meal periods a day – breakfast, lunch, high-tea, dinner and supper. It takes a lot of you actually. Hence, it becomes very challenging for women to run between the two – her job and her house – and probably, that’s the reason why we see less women in this field and more testosterone driven kitchens. At Sofitel Mumbai BKC however, we encourage our teams and women in particular, to maintain a healthy work-life balance. No extended hours and overtime at work is promoted and we try to ensure that they are able to manage their professional and personal time effectively.”

Kamlesh Salve, Executive Chef, The Mirador Mumbai states, “Historically, women have always done the cooking at home but that has been seen as domestic and not a 'real' job. Most restaurateurs are more likely to hire a young man because they can run around the kitchen faster with heavy pans and create more business. Men have greater muscle power, yet women are calmer in the kitchen. The real crisis in the industry unfortunately falls upon reputation. As a society we suffer from a conflict that it is reputable for women to have culinary aptitude, but when it comes to them pursuing a professional career in such talent, the general consensus drops dramatically. There is a notion that has been historically ingrained in our culture - established by both culinary professionals and diners alike - that the industry is male-dominated for a reason. There are those who think that men possess the skills, aptitude and resilience to survive the pressures and hardship of a professional kitchen, that women do not.”

Chef Vanshika Bhatia, of 'Together at 12th' Restaurant at the Le Meridien Gurgaon, reveals, “F&B is a predominantly Male dominated industry and historically the reasons for that have been manifold- for instance, late hours, highly physical work and high paced, heated environment, just to name a few.”

However presenting the other side of the coin she says, “Women have always been the Masters of the Home Kitchen and modern chefs are breaking the above misconceptions of Women not being able to take on the pressures of the commercial kitchens, every single day. These are the



Neeraj Rawoot

chefs that are paving the way for other Young Women who want to be a part of the Industry. Since the gap has been so wide, it will definitely take some time to close it but the trend of women working in commercial kitchens is going upwards steadily.”

She is sure about the continuing rise of women in the F&B kitchens, narrates her rise in the industry as an example. She states, “I myself was the Head Chef of Ek Bar in Delhi at the age of 23.” She continues, “I started my culinary journey right after class 12th when I joined Le Cordon Bleu London. I immediately jumped into working and spent time in the kitchens of the best restaurants in the world like Noma Copenhagen, Gaggan, Thailand and Junoon, Dubai before I decided to come back home to India. I then worked at Olive Delhi post where I was made Head Chef of Ek Bar, one of the many restaurants under the Olive Umbrella. It was just post this that I decided I want to run my own kitchen because I had a lot of stories I wanted to tell through food and I wanted the freedom to be able to do it. At the age of 25, I opened 'Together at 12th' in



Kamlesh Salve

Le Meridien Gurgaon.”

Ruby Islam, Pastry Chef, ITC Windsor, Bengaluru, avers, “The notion of fewer females in the kitchens is a changing one, with more women coming forward to challenge the status quo. Today, a large number of women run owned-businesses and manage luxury hotel kitchens.”

Citing her own example, she narrates her journey through her career thus:

“Having pursued my Bachelors of Hotel Management at Christ University, Bengaluru, I joined the KMT Program with ITC Hotels in 2013. I specialized in Bakery & Pastry after having worked in the kitchens of Taj Mahal Palace, Mumbai as a trainee. During my KMT days, I worked at the ITC Maurya, New Delhi, and subsequently was part of the pre-opening team at ITC Grand Bharat. My first stint as a Jr Sous Chef was at the ITC Gardenia in pastry under the leadership of Chef Arvind Prasad. With Chocolate being our newest venture- ITC Hotels & FBD launched Fabelle- Exquisite Chocolates and I headed the first boutique at the ITC Gardenia, following which I standardized opening the brand across the chain.

“Prior to my current posting as the Pastry Chef at the ITC Windsor and heading bakery, pastry and Fabelle, I was also part of the kitchens of ITC Sonar, Kolkata, where I worked as the Sous Chef- Bakery, Pastry & Fabelle.”

Rimzim Singh, HR Manager at Hotel Crowne Plaza New Delhi Rohini asserts that in the present day industry females are increasingly being employed as chefs and F&B professionals in the hospitality industry. She adds, “Media has played an important role in glamorizing a chef’s life and their passion to work in kitchen. Female chefs have brought in a new energy to professional kitchens and they are running the restaurants successfully. It will take time but soon we will see women and men ratio same in F&B and culinary field.”

Kitchen Queens

It seems that sexist gender roles continue to dictate that the kitchen and home are the workplace of the woman, and the outside world – and its kitchens – the workplace of men. Very few women have thus made it as chefs in the kitchens of high-end Indian restaurants and cafés.

If one steps into the shoes of a female culinary student one finds that they have spent hours studying tirelessly to achieve



DISPENSING, REINVENTED!

the Original

SAUCE DISPENSING

Toasting & Steaming Solutions



FIRST IN FIRST OUT (FIFO)

FIFO Bottle™ dispenses from the bottom through a non-drip silicone valve and fills from the top.

Simply Squeeze FIFO Bottle™ to open the valve and dispenses product. Once you let go, the valve automatically closes. Bottom dispensing decreases service time and minimizes sauce waste.

Fast Dispensing

Simply pick up and squeeze. Sauce sits at the nozzle. No need to flip the bottle over.

Sauce Savings

FIFO Bottle™ sauce dispensers save up to 15% more sauce compared to a standard bottle. With FIFO Bottle™, your sauce is not washed down the drain.

Easy to Clean and Fill

Wide-mouth openings at both ends allow easy cleaning.

More Sanitary

Dispensing tip never touches counter surface or food.

Proper Food Rotation

The first-in, First-Out (FIFO) concept ensures proper food rotation by enabling the sauce that was first put in the bottle, to be the first that comes out of the bottle.

Multi-Purpose Valves

The FIFO Bottle™ multi-purpose valve can dispense sauce ranging in viscosity from water to caramel, with particles up to 1/8 inch. Whatever your sauce dispensing needs, FIFO has a solution.

NSF Approved

Dishwasher Safe

FIFO Bottle™ Sizes					
OZ	12	16	20	24	32
ML	355	473	591	710	946

ORGANIZE



SAUCE LABELS

24 LABELS PER SHEET. CUSTOM LABELS AVAILABLE.



SILICONE FUNNEL



Used by: Subway | Burger King Teco Bell and many more..



Toasting
Antunes is a recognized leader for toasting because of our rapid toast technology that revolutionized the foodservice industry. By producing a perfectly golden bun in as little as 10 seconds, our products obsoleted batch toasters and allowed operations to build and serve sandwiches on freshly toasted breads without causing any delay. Today, Antunes has more than 100,000 units in operation throughout the world. For buns, bread, or muffins, Antunes toasters are trusted because of their reliability and quality.

Steaming
Antunes has helped foodservice operations of all sizes expand and improve upon their menus with the power of steam. With just plain tap water, our steamers cook food consistently and thoroughly while maintaining the original colors, flavors, and nutrition. More importantly for operations, our steamers cook food quickly and easily, eliminating the need for time-consuming methods that require constant attention. For everything from a full, portion-controlled meal to a hot finish to a fresh sandwich, Antunes steamers deliver with precision and accuracy.



Miracle Steamer
Miracle Steamer Eliminate the long waits for preparing hot menu items. The Miracle Steamer uses plain tap water to heat and cook foods. The generator converts water into super-heated dry steam for intense top-down heat. This cooks and finishes foods to keep the original textures, colors, flavors, and nutrients. This unit features two steam options—push-button action for instant results and a programmable timed cycle for longer steaming.

- Top-down steamer with spatula or drawer
 - Stainless steel construction
 - Programmable steam cycle
 - Consistently finished product
- Instantly turns plain tap water into super-heated dry steam



Gold Standard Toaster
The Gold Standard Toaster has a dual belt feed for toasting crowns, heels, and clubs. This toaster features a new design that saves valuable counter space and increases energy efficiency.

- Energy-efficient design reduces heat loss and prevents outside surface of toaster from becoming hot
- Electronic temperature controller ensures proper calibration and even toasting
- Continuously moving dual belt allows immediate feeding of buns without sticking

- Fully programmable temperature and motor speed settings
 - No bun marking



Vertical Contact Toaster
Bring out all of a burger's flavors by serving it on perfectly toasted buns. The Vertical Contact Toaster gives buns a consistent, golden brown finish so they won't soak up the juices of the ingredients and the burger will stay firm and delicious. A complete line of toasters and features are available to meet the needs of any business, including butter wheels, bun feeders, bun chutes, and heated bases.

- Dual-sided platen for additional toasting capacity
 - Stainless steel construction
 - Space-saving vertical design
 - Continuously moving conveyor
- Separate compression adjustments for the heel and crown
 - Easy to operate and clean



Authorised Distributors in India.

D K G Sales Pvt. Ltd.

Head Office
72/5, 2nd Floor, Street No. 3, East Moti Bagh,
Sarai Rohilla, Kishan Ganj, Delhi -110007, INDIA
Phone : 23696742, Mobile : +91-9999826782, 9810007063

Branch Office
Plot No.132, Udyog Kendra,
Extn.II, Greater Noida,
Gautam Budh Nagar, Uttar Pradesh-201306

E-mail: sales@dkgSpl.in, director@dkgSpl.in, Website: www.dkgSpl.com

Our Assisted Partners



their dreams. They toil in the kitchen to carve their own niche. After this, imagine them being told that they are not as good as the male chefs!

They are treated as second fiddles in F&B outlet kitchens. Isn't it time they took the reins in their hands and demanded an equal – if not superior – role in the kitchens as their male counterparts?

Neeraj believes that women can definitely be excellent leaders in the restaurant kitchens. He states, "I strongly believe that women can become excellent leaders in professional kitchens and there are some well-known examples of outstanding women head chefs in our own country – although the numbers are not large, but they are very promising. It is essential that women, in whatever capacity or job role, are respected, made to feel safe and given the opportunity to work shoulder-to-shoulder with the men in the kitchens. That is what's required to bring in more women hands in our professional kitchens."

Rimzim says that women's versatility makes it all the more important for them to be treated on equal footing as male chefs, particularly at a time when COVID 19

is having an adverse impact on all aspects of life. She avers, "A woman's inclination towards kitchen and versatile knowledge and experience in the said field should itself act as a self-motivation to drive her to a leadership role. Additionally hospitality industry has left no stone unturned towards gender diversity, especially when it comes to advanced employment opportunities for females in various departments. IHG itself has career progression program for High Potential Lady Colleagues like "Climb, Lead and Rise for Elevated roles at managerial level and HOD level."

She opines that there are lower number of female chefs as "it involves a lot of physical hard work with long hours of working. However this has eventually changed with latest machines and equipment which has replaced physical work load and organizations are now really focused for work life balance and vacations paid offs."

Kamlesh asserts, "Women have already proved themselves as leaders when it comes to F&B and kitchens. Right from running a home kitchen or a commercial kitchen women have done it all. Women have been in leadership positions in F&B.



Rimzim Singh



Vanshika Bhatia



Ruby Islam

Recipes By Women Chefs

Jasmine Milk Chocolate Ice Cream

By Pastry Chef Ruby Islam, ITC Windsor

Ingredients

Full Cream Milk- 1 litre
Fresh Jasmine Flowers - 200 g
Allow the cold milk to infuse with fresh jasmine flowers for 12 hours, refrigerated.
Infused Milk - 850 gms
Milk Powder - 50 g
Liquid Glucose - 60 g
Honey - 50 g
Ice cream Stabilizer - 10 g
Heavy Cream - 200 g
Milk Chocolate - 200 g
Heavy Cream - 75 g

Method

Make a ganache with milk chocolate and heavy cream and cool to 25 degrees.
For the Ice cream- use the infused milk as the base- and mix in liquid glucose, honey, milk powder, and heavy cream- warm to 40 degrees Celsius, add the stabilizer and bring to a boil. Cool down to 4 degrees and mix in the milk chocolate ganache. Refrigerate for 12 hours and

churn the next day.

Enjoy with a few sprinkles of sea salt and milk chocolate shavings.

Chocolate Mutton

By Chef Vanshika Bhatia, Together at 12th.

Ingredients

Mutton with bone 1kg
Garlic 50 gm
Salt 20 gm
Pepper to taste
Rosemary 1 sprig
Cocoa powder 20 gm
Carrots 150 gm
Onion 100 gm
Dark cooking chocolate 50gm

Method

Marinate the mutton with salt, pepper, garlic, rosemary and cocoa powder in the refrigerator overnight.
Next day let the mutton come to room temperature.
Sauté the roughly chopped carrots and onion. When the vegetables turn golden brown, add the marinated mutton. Cook in a pressure cooker till 5 whistles.

Thus, I believe that there should not be a gender bias and hiring should be based on talent."

Ruby believes that women chefs have already proved their ability by not only being chefs but also chef-owner entrepreneurs. She adds, "There has been a steady incline in both – chefs and enterprising entrepreneurs – and there is only room for more."

She asserts, "In today's world, it doesn't matter whether you're a man or a woman. One will definitely excel if one brings relentlessness, grit and passion to the plate."

And this is definitely true as several women restaurateurs are, at present, disrupting the Indian hospitality industry with unique concepts. There are examples of several women breaking the stereotype roles in food and beverage and hospitality industry.

Outstanding Examples

The ground for ladies to make a dent in different professions, including F&B, was prepared by ladies of grit and determination. The name of Bhiku Manekshaw springs immediately in the

mind when one contemplates on lady chefs. From the 60s to the 80s this formidable lady guided the Capital's culinary affairs from the kitchens of the cultural bastion that was the India International Centre (IIC). The country's first Cordon Bleu-trained chef, Manekshaw left an indelible impact on Delhi's palate.

Neeraj reveals, "There are several women chefs running their own restaurants." He believes that being an entrepreneur is better since it allows you the opportunity to decide on the size and time of operation. This allows one to focus on cuisine. He adds, "You have a much relaxed platform as compared to the rigid structures of a hotel kitchen. Some of the Chefs I know are:

Anahita Dhondy – She has started an exclusive curation of food and beverage services

Ritu Dalmia – chef and co-owner of the popular Italian restaurant Diva in Delhi

Megha Kohli – head Chef and head of operations at Lavaash By Saby

Pooja Dhingra – owner of bakery chain, Le15 Patisserie, that specialises in macarons and a host of French desserts.

"There are another set of lady home

chefs who run kitchens from their houses, and who we, at Sofitel Mumbai BKC, have associated with in the past and made them cook in our kitchens for specific food festivals and cuisines. They are:

Gitika Saikia – Assamese food

Ajanta Burman – Bengali and Goan

Ananya Banerjee – Bengali

Sumitra Kalapatapu – Andhra Brahmin food"

Kamlesh states, "The kitchen hierarchy ranges from a Commie to the top most position of Executive Chef's and Corporate Chef's.

Many female chefs have achieved a role of every ranking. Some of them are:

Chef Gunjan Goela

Chef Veena Arora

Chef Garima Arora

Chef Ritu Dalmia

Chef Nita Nagraj

Chef Kainaz Messman

Chef Sandhu

"These are just a few of them. In years to come home chefs will also play a vital role."

Vanshika disclosed, "Chef Radhika Khandelwal, Chef Megha Kohli, Chef Anahita Dhondy are few other chefs in



GET ORIGINAL PRODUCT FROM HERE



NEVER COMPROMISE IN PRODUCT QUALITY



Bar BQ



Riser



Chafing Dish



Snack Concept



Bar BQ Grill



Napkin Holder



Napkin Holder



Snack Concept



Snack Trolley



Snack Concept



Condiment set



Snack Wire Stand



Steel Riser

DHANJAL INDUSTRIES

Contact us:

📍 E-163, Sector-2, DSIIDC Bawana Industrial Area, Delhi-110039

📞 +9810989923 | 8178055336 | 011-20876392 | 📧 info@dhanjalhotelware.com | 🌐 www.dhanjalhotelware.com





Chef Manisha Bhasin - Corp. Ex. Chef- ITC Hotels presenting Pastry Queen 2019 title to Chef Tanvi

Delhi NCR who have been leading their kitchen brigades and of course there are so many more all over India and the world."

Ruby adds a few more names to this list, from the ITC group. They are:

Chef Manisha Bhasin- Corporate Executive Chef- ITC Hotels.

Chef Madhu Krishnan- Corporate R&D Head- ITC Hotels

Chef Parul Kapoor- Executive Chef, ITC Rajputana

Kitchen Hierarchy

The hierarchy of chefs offers a repertoire of French titles. Often there are various types of chefs operating in one kitchen. They all have different tasks. Chefs – men as well as women – rise from apprentice upwards.

So what are the different ranks of chefs?

Rimzim says, "The different ranks of chefs are: Corporate Chef, Executive Chef, Executive Sous Chef, Chef De Cuisine, Sous Chef, Chef de Partie, Demi Chef De Partie, Commis-1, Commis-2, Commis-3, Apprentice." She adds, "There are many Lady Chef leaders across the industry and we will most likely continue to witness this increasing in coming years."

Neeraj elaborates, "We follow the French terminology in Culinary Hierarchy. Starting is from the Commis level, then

Chef de Partie, Sous Chef, Chef de Cuisine, Executive Sous Chef and the highest position is of course, the Executive Chef.

"There are many Lady Chefs who have reached the top of the ladder. However, it is ironical that the gender that rules our homes and has held our household kitchen fortress in high standards, are few in numbers when it comes to hospitality kitchens. To name a few – Nita Nagraj, Manisha Bhasin, Madhumita Mohanta, Madhu Krishnan."

Vanshika avers, "The Executive Chef or the Head Chef are the most senior positions of Chefs. Each person in the hierarchy is important and has a role to play in the final dish that reaches to the table. Be it the intern who's peeling the garlic, the Commis making the stock, the CDP making the dish, or the Sous Chef doing the Costing and Vendor Approvals or the Head Chef who is running the pass. No one is dispensable."

Tips for new comers

Though currently we are going through a difficult phase due to the pandemic, the work of a chef has to continue if the restaurant has to survive and make a name for itself. New female chefs need their self-image to be boosted in order to give off their best.

Rimzim states, "Entering the F&B

sector is a great way to shape your dreams. However, the initial years of your career can be quite demanding in terms of physical hard work and mental balance. If you are passionate about food and beverage then there is no limit to your success. This line is not only has a promising career but can also open entrepreneurial avenues after a decent experience."

Ruby too is of a similar opinion. She says, "If your dream is to be a creative, experience oriented, passion driven F&B personnel, then pursue it relentlessly. The world could find plentiful reasons to discourage you from being a women head chef or owner of a restaurant. But let your work and persistence speak for you."

Vanshika avers, "If you are passionate about it, you won't have a problem sticking to it. Hospitality isn't easy, it's a demanding career choice and I love every second of it. Ask questions, keep a watchful eye, don't say no to any task being given to you no matter how insignificant you think it is. Just keep your mind and heart open so you can take in all the knowledge being given to you."

Kamlesh clarifies, "Every F&B outlet is different, but it will be successful if designed correctly – from your menu to your team. You want your hotel F&B outlet to be not only a profitable and one but also one of the best amenities. For this, I would suggest you follow these rules:

Focus on the Financials

Don't cut cost, control the wastages

Need to do multitasking

Maintain quality standards

Be consistent

Be creative

Be with the current trends

Concluding, one may state that today's women are exuberant, fearless and ambitious. They don't wait for validation. Today's women are the women of the future. They are the pillars of strength in any home who effortlessly who manage and organize the entire house. They are capable of achieving the same status in the F&B kitchens.

Neeraj claims they will achieve this status. "There is no time frame for this but in the changing trend of the past decade, where more and more women have been making their presence felt the time is not far when they will attain an equal if not higher status than male chefs."

So, on this women's day, let us say 'Viva le women'!

WE TAKE CARE OF YOUR DISHWASHING

Your Dishwashing Specialist.

Commercial dishwasher for perfect cleanliness & hygiene.



The new C50. A modular system for high capacity and hygiene

- Effective Filtration
- High Performance
- Saves Water
- User Friendly
- Saves Time
- High washing Capacity

Commercial Dishwasher Range:



Under Counter Dishwasher



Hood Type Dishwasher



Rack Conveyor Dishwasher



Multi-tank Rack Conveyor Dishwasher

Detergents Range:



PAN India Service Support & AMC Service
Toll Free Help Line No.

1800 1035 913*

(Mon to Fri, 9:30 AM to 5:30 PM,
Saturday, Sunday & Public holiday- Closed)

Head Office :

Winterhalter India Pvt Limited

Plot no 269, Sector 7, IMT Manesar - 122050, Haryana

www.winterhalter.in | email: info@winterhalter.in



Maintaining Hygiene Amidst Pandemic

Restaurants which were humming with activity and serving a full house on Valentine's Day last year are now, with strict observance of social distancing and other SOPs due to the pandemic, having only about 25% of the occupancy. This unprecedented situation has arisen as the people are concerned about their health and are not sure about whether it is truly safe to dine out – or even order food from the neighborhood restaurant. Under these circumstances, it is imperative for F&B outlets to be vigilant about food safety. **Ashok Malkani** tries to find out the steps being taken by the industry not only to maintain hygiene in the kitchens but also to keep the guests informed about these measures to gain their confidence. And, with increasing costs, due to observance of high level of hygiene as well as having low number of diners due to maintenance, how do these F&B outlets manage to balance the revenue?

The culture of eating out, which had been steadily evolving over the last decade and a half, has been badly affected by the pandemic. Pre-pandemic food services in India which, according to the National Restaurant Association of India, was estimated at Rs 4,23,865 crore, has been badly hit. Though, with the easing off of the lockdown the restaurateurs have been slowly trying to restore faith in their guests about the necessary steps being taken to ensure safety of the diners by following all the SOPs set in place by the health authorities,

the guests are cautious about the hygiene being followed in these outlets.

With new versions of virus being discovered, the panic among the people has not decreased, resulting in very little favourable effect on the F&B outlets. These establishments are making all efforts to convince the customers about their safety. With strict observance of social distancing, there is less contact-dining experience for diners. On the technical front the restaurateurs have started usage of QR, non-human interference except for service of food at the table. Besides, there

has been a high level of hygiene for staff as well as adherence of strict cleanliness and sanitization in the kitchens.

People believe that corona virus can be spread through food and so they want to be assured about how the raw food is cleaned and cooked and served at the table.

It may be mentioned that while research into the COVID-19 virus is ongoing, it has so far been found that the virus is transmitted through direct contact with respiratory droplets of an infected person (through coughing and sneezing), and

touching surfaces contaminated with the virus. At present there is no evidence of people catching the COVID-19 virus from food

Importance of Hygiene and Sanitization

Mustakeen Sheikh, CEO, Realta Ventures and spokesperson of London Bubble Co. declares, "The pandemic has caused ripples across several industries and has severely impacted the sheen of the F&B sector. Hygiene and sanitization have emerged as non-negotiable. Even though there is no evidence of transmission via food, the F&B industry has had to ensure that people are aware of the precautions taken to gain customer confidence.

"While large-format brick and mortar stores were important touch points for brands to engage with the audience, the contagion has fuelled the need for hybrid, contactless solutions laying equal emphasis on the online and offline ecosystem. In both formats, maintaining hygiene from a product standpoint remains our key focus so that food safety is not compromised. It's the prevention of contamination that is of highest importance across all our London



Bubble Co. outlets."

Kamlesh Salve, Executive Chef, The Mirador Mumbai, asserts, "Covid 19 is not a food or water borne disease. It is transferred from human to human and contact surfaces."

He adds that the scare of the virus has affected not only the F&B segment but the entire hospitality industry. "The guest who walks into a hotel or a restaurant is concerned about his safety," he says.

Speaking about food safety he disclosed,

"The first recipe of the safe food is hand wash. Before starting any work in the kitchen or coming into the kitchen you should wash your hands for 30 seconds. To maintain kitchen hygiene we wash and sanitise out worktops, knives and utensils. The dish clothes are also washed. Most of the restaurateurs use separate chopping boards for veg and non-veg food. Another essential step for food safety is keeping raw meat separate from the cooked and semi cooked meat. One should store



KPL INTERNATIONAL LIMITED
chemistry of partnerships

KPL International Limited, a major partner with more than 35 Global manufacturers catering to various Industrial sectors. Established about two decades ago, KPL specializes in the marketing and distribution of quality products in India, mainly in the field of **Food, Pharmaceuticals, Chemicals, Polymers, Paper and Paper Chemicals**, sourced from globally acclaimed manufacturers. With over 3,000 customers, KPL continues to grow with a varied market segment along with the recent area of focus; Renewable Energy.

Over the years, KPL International Ltd. has formed excellent partnership with Mitsubishi Gas Chemicals, Singapore in India for their Oxygen Absorbing Active Packaging products.

ONE OF THE
TOP 100
CHEMICAL DISTRIBUTORS
IN THE WORLD BY ICIS



'OXYGEN'; ANOTHER ENEMY OF FOOD STORAGE LIFE.

AGELESS®

"AGELESS", world's top brand of Oxygen Absorbers developed by Mitsubishi Gas Chemicals. It absorbs oxygen in sealed container in a way where the Oxygen concentration is 0.1% or less, possible to enhance the shelf life of food by eliminating its ill effects; keeping the food Fresher. Healthier. Tastier.

Ageless Prevents:

Moulds, Aerobic bacteria & other insects growth	Oil & Fat Oxidation & Rancidity
Discoloration of food	Loss of Nutritional Value

MITSUBISHI GAS CHEMICAL

PIONEER INNOVATOR LEADER
in oxygen and gas scavenging systems

AGELESS is Safe & FDA Approved for direct contact with food & related products.

raw meat on the bottom shelf of the refrigerator. The fridge temperature should be below 5 degree C.”

Solutions to Clean Vegetables & Fruits

With people being extra conscious about maintaining food hygiene, the F&B outlets are taking extra steps to assure guests that they maintain the kitchen surroundings and food items hygienically cleaned. In the current corona virus pandemic washing of fruits and vegetables has gained more prominence. There are several people making use of vegetable washes (which are being highly advertised), disinfecting liquids and detergents for cleaning veggies and fruits.

While many food scientists advise against the use of chemical based products due to the potential risk of residues and chemical buildup, some suggest that a diluted mild detergent solution can be used with proper rinsing of fruits and vegetables with clean water, especially when chances of viral contamination are higher.

Kamlesh avers, “Personally I do not use any solutions available in market which claim that cleaning vegetables with solutions can kill virus. I believe the best way to wash and sanitize your vegetables is with chlorine water. You can use a solution made of 4ml of chlorine in 10 ltrs of water or 50 ppm (parts per million).”

He is of the view that proper storage of vegetables and meats is essential for an F&B outlet. He says, “The veggies have to be sanitized immediately on arrival before storing them for future use. In case of packaged material we, at The Mirador Mumbai, quarantine the boxes for 24 hours.”

Mustakeen states that washing of vegetables and meat does not arise at his outlets since majority of the offerings on the menus in their outlets comprise of baked products. He adds, “We rather give importance to proper cooking to make sure there is no concentration of any kind of pathogens in food. Additionally, the virus has proven to be susceptible to food cooked at a recommended temperature so we use a food thermometer to minimize the slightest chances of contamination of our menu offerings.

“Our staff also frequently wipes down counters, sanitize cookware and utensils and other high- contact surfaces. We use an industry approved alcohol disinfectant and disposable wash cloths to wipe down surfaces to avoid contamination. We also



Mustakeen Sheikh

ensure that containers and packages are sanitized.”

All round Kitchen Hygiene

Cleanliness and hygiene does not merely mean cleaning the vegetables and meat but also ensuring that the chefs follow strict adherence to food safety. Some of these methods are:

- Food handlers must thoroughly wash their hands with soap and water for at least 20 seconds before preparing food
- Using separate chopping boards to for uncooked vegetables, meat and fish
- Cooking food to recommended temperature
- Keeping perishable items refrigerated or frozen, paying attention to product expiry dates
- Using clean utensils and plates.

Mustakeen states, “During these unprecedented times, we have invested heavily in training and development of our staff to enable them to smoothly manage end-to-end operations - right from receiving an order to dispatch. We’ve also outlined a 14-point memorandum that states all safety protocols, which works as



Kamlesh Salve

an assessment list to monitor sanitization, providing reassurance to all stakeholders.

“Personal hygiene is imperative among people who handle food and packaging at the backend. We’ve realigned the flow in terms of managing raw materials and limiting the number of handling staff in compliance with safety guidelines. In addition to this, our outlets undergo timely audits to ensure food safety practices are resolutely followed.”

Kamlesh stressed, “Various areas of Food Establishment (such as food preparation, production area, stores, packaging area, service area, waste disposal area, etc.), transport vehicle should be cleaned with soap and water, followed by disinfection (using freshly prepared 1 percent Sodium hypochlorite solution against coronavirus). The same chemical mixture has to be used to sanitize the walk-in and deep fridge including SS racks, the ceiling, walls, flexible rubber, cooling fan, ventilators, curtains. At The Mirador, we also make it a practice to sanitize the food crates with 100 ppm of chlorine for 10 minutes. The same cleaning and sanitizing process should be followed for all vertical and table top refrigerators.

The other practices that should be adhered to are:

- Use of gloves at any given time while handling veg or non-veg as well as handling perishables or non-perishables
- Dedicated chopping boards
- Sanitization of vegetables and meats
- Avoiding usage of kitchen dusters. Instead the restaurateurs should use disposable paper roll for cleaning
- Usage of cling wrap and silver foil.
- Personal hygiene
- Waste management
- Pest control
- Environmental hygiene
- Informing guests about safety measures

Several restaurants have not only adopted hygiene in the eating out places but have also taken steps to protect their home delivery boys from exposure to corona virus. Many restaurants have begun doing contactless drop offs where the customer pays in advance and the delivery person leaves the package of food outside the door so that two parties don’t interact.

But the restaurants, which normally rely on dine-in guests for business, have to convince the guests about the safety measures adopted by the restaurants. So how do the restaurateurs enlighten the



METINOX

www.metinoxindia.com

*We Create
Masterpieces*

Gold Luke



CUTLERY, TABLEWARE & KITCHENWARE



Spatulas



Angular Spreader



Chafing Dish Spoon



Spoon Rest



Fry Pan
(wooden Base)



Napkin Holder



Salt N Pepper



Serving Tongs



Ice Bucket



Tri Ply Cookware



GN Pan



Silicon Tools

METINOX INTERNATIONAL

M-20,1st, Floor, Badli industrial Area, Delhi-110042

facebook.com/Metinox-international-1802979789941750

metinoxint@gmail.com

Customer Care No. 011-49065718



customers about the precautionary steps being taken for their safety?

Kamlesh states that some of the measures taken by the restaurant can be gauged by the customers due to their easy visibility. He reveals, "At our F&B outlets, we adopt the following methods for guests' safety:

- Use of gloves while working
- Use of face mask and shield by all employees
- Social distance while working
- Sufficient space between seating to ensure social distancing
- Use of QR code for menu scanning
- Use of disposable cutlery or crockery
- Customers are encouraged to avoid cash and use online models for each payment or transaction

"There are several other measures which are adopted but are not visible. They are:

- Proper hand washing and sanitization by the staff
- Regular temperature check of staff and vendors during the entrance gate
- If regular plates are used, they are, after usage, closed in disposable plate cover and washed at 65 to 72degrees C for washing and rinsed between 75 to 82 degrees C
- Sanitization of each table and chair after each operation

"These are only a few of the safety

measures adopted at our hotel and we keep our diners duly posted about these precautions taken by us."

Mustakeen declares, "The pandemic has laid undisputed importance on safety and hygiene across all formats – delivery as well as dine-in. Fortunately, we have always been compliant to the guidelines prescribed by Food Safety and Standards Authority of India and have held hygiene practices in high regards. However, certain new implementations like temperature checks and regular sanitization were communicated through our social media platforms. We wanted to take into account the minutest of concerns of our consumers and even reached out to them to understand their apprehensions and worked at etching it in our SOPs for our kitchen staff, servers and valet riders. The most important step in retaining the confidence of the customer was to keep them informed at all levels - cooking, packaging and delivery and we rightfully managed to do so through our various owned assets."

Making Ends Meet

Due to extra precautionary measures to ensure customer safety and complying with the mandatory social distancing, resulting in curtailment of customers, it becomes difficult for the restaurateurs to make ends meet. Added to this is the rising cost of goods raising the cost of operations of the

establishment.

So how are the F&B outlets preparing to manage the rising costs, without affecting the inflow of the customers?

Mustakeen concedes that it is difficult for the outlets to make ends meet. He says, "The decline in footfalls has compelled businesses to restructure and realign operations to adjust to the new normal. The F&B industry has had to swiftly adapt to the economic climate and maintain smooth business continuity. A portion of the rebuilding efforts is prioritizing preemptive investments in food hygiene and sanitization. We've invested in purchasing protective equipment and sanitization of units to create a safe dining experience for our customers. To manage these challenges and regain profitability, we are adding cost to our COG and absorbing the same. The industry has adopted to new ways to sustain operations by embracing digital transformation. The low cost-high impact investment is leading the F&B industry on its path of recovery."

Kamlesh states, "Governments around the world consider the food industry as strategic sector during this crisis. Since the F&B industry is helping communities around the globe by providing them essential food, we are socially responsible for keeping our activities going."

He adds "In some hotels and restaurants the guest are charged extra due to the extra expenditure being incurred to maintain high standards of hygiene. On the other hand some establishments take the onus of bearing the extra costs and do not charge any additional cost."

In other word, there are additional costs but it is up to the establishments to charge extra or to reduce their percentage of profit.

Conclusion

Guidance from the World Health Organization says, "Current evidence on other coronavirus strains shows that while corona viruses appear to be stable at low and freezing temperatures for a certain period, food hygiene and good food safety practices can prevent their transmission through food."

That said, there is little doubt that food hygiene and good food safety practices are essential to attract not only dine-in crowd in the F&B outlets but also encourage people to order at home. Thus, food service operators must be rigorous in following safety, cleaning, and sanitation protocols. ■



Panasonic®

Serve More Customers in Less Time

Improve Productivity & Increase Profitability with Panasonic

COMMERCIAL MICROWAVE OVEN

- 1800 WATTS** 1800W Of Cooking Power
- Dual Power Feed** for more consistent even cooking
- 2 Magnetrons**
- SS** Stainless Steel Cabinet & Cavity
- 15 Power Levels & 5 Stage Cooking**
- 30 Preset Menu Programs**



NE-1853

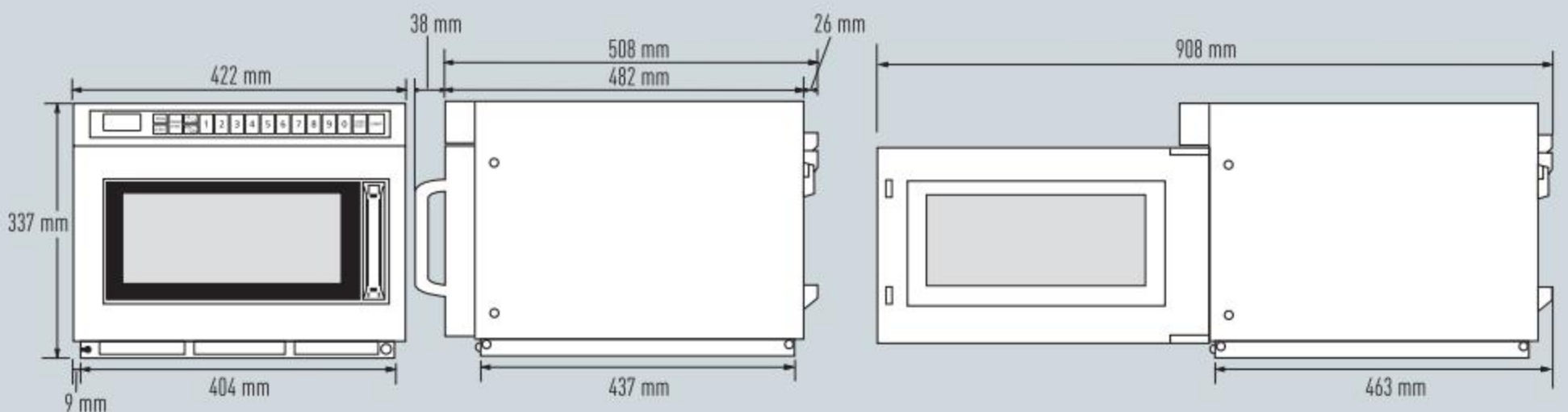

Panasonic Appliances India Co Ltd., 6th Floor, "SPIC HOUSE" Annexe, No. 88, Mount Road, Guindy, Chennai - 600 032.

ALL INDIA ENQUIRY: Mr. Rahul +91 86556 66867 Mr. Vishal +91 81780 92854, +91 98712 93394

Follow Panasonic Cooking India on: VISIT: www.panasonic.com BLOG: www.panasonicsmartcookbychandribhat.com

Revival for Restaurant Business



By Jhuma Biswas

Restaurant business in India is slowly recovering from the severe economic jolts it suffered due to successive lockdowns but it would still require some more time for India's restaurant business to reach pre-Covid levels of revenues and growth.

On end October 2020, The Federation of Hotel and Restaurant Associations of India (FHRAI) wrote to the Prime Minister, appealing for a hospitality-specific relief package for saving India's hospitality sector from collapsing. The association said that if a favourable policy for survival of India's hospitality sector was not made then at least 40-50 percent restaurants and 30-40 percent hotels in India would have to close shop, resulting in millions of job losses. Already several restaurants have closed down in India resulting in plethora of job losses in the restaurant and bar business of the country.

We cannot have much hope on the callous government at the centre. In the recently tabled Union Budget for the 2021-22 fiscal, the centre reduced the budgetary allocation for the Ministry of Tourism by 19 percent from Rs. 2,500 crore in 2020-21 to Rs. 2026.77 crore for the forthcoming

fiscal of 2021-22. The reduced budget for tourism does in turn have the serious potential to adversely affect the restaurant business in India.

The restaurateurs in India need to help themselves to quicken their revenue growth, which may be reflected in profits too. However, we have to keep in mind that in the present context, majority of restaurants in India would prefer those routes towards revenue and profit growth which require less investment.

Hygiene for Confidence

One of the ways they can help garner more guests is through hygiene route. The restaurants in India should not only adhere to stringent hygiene protocols but should showcase the hygiene protocols that they adhere to through social media platforms. This measure would help to generate more confidence among their potential guests regarding visiting restaurants and some of their potential guests may turn into real guests in the short run.

As lockdowns have weakened the Indian economy, people on an average are having less disposable incomes than before. Restaurants in India should thus slightly

reduce their profit margins and provide their food & beverages at slightly discounted prices without reducing the quality of their offerings. This writer believes that by doing so they could easily cover this revenue loss through more sales.

In other words, in this economic climate more people in India would be willing to visit those restaurants which offer their products at discounted prices without discounted quality.

Uncommon Food Festivals

Restaurants in India can generate additional revenues during these trying times through organising food festivals focusing on various uncommon cuisines of India and abroad in the Indian context (such as Nagaland Food Festival, Spanish Food Festival, Greek Food Festival, etc.) and publicising those food festivals through cost-effective social media platforms. These will cater to the growing number of people who are eager to experiment with new uncommon types of cuisine.

Of course, it goes without mention that only those restaurants operating in the organised sector which have some financial muscle can organise food festivals



to augment their revenues. Restaurants somehow surviving on the brink of collapse cannot afford to undertake this measure. Moreover, food festivals should be organised while keeping the profile of the restaurant and its clientele in mind.

Reducing Wastage

Restaurants in India can also take a pragmatic step towards their profits by

ONE STOP SOURCE FOR FOOD & KITCHEN EQUIPMENT

MAKE ICE CREAM YOUR BUSINESS

ICE CREAM MACHINERY

CONTINUOUS ICE CREAM FREEZER

SOFT ICE CREAM MACHINE

ICE CUBE MACHINES

Ice-boy

KOLDIN

Keep Fresh Refrigeration Machinery

COLD ROOMS, PROCESS CHILLERS
CONDENSING UNITS, EVAPORATORS & CONDENSERS

HINDUSTAN GROUP

COOLING THE NATION SINCE 1947

KITCHEN EQUIPMENTS

SERVEX

VERIKOLD

Refrigeration Equipment

REFRIGERATED DISPLAY COUNTERS
UPRIGHT DISPLAY VISI COOLER
COLD DRINK DISPENSERS

DEEP FREEZERS & VISI COOLERS

Haier
Inspired living

VOLTAS

ISO 9001 : 2015 Certified

Head Off. : 2, 4 & 5, Netaji Subhash Marg, Darya Ganj, New Delhi- 110002

Tel. : 011-23271898, 2327725, 2327735, 2328884, 4967777 (100 Lines)

Fax : 011-23271152

Email : hgrop@gmail.com

Website : www.hgroupworld.com

HINDUSTAN REFRIGERATION STORES

DELHI NOIDA GURUGRAM BHIWANDI CHENNAI

AUTHORISED DISRIBUTOR

RefComp Danfoss EMERSON Climate Technologies FRITERM Chemours Opteon Freon

reducing wastage of food products and other resources in their daily operations. Here it deserves a mention that food wastage is not only morally and ethically wrong, not only does it create huge economic losses but it is also very much detrimental to our fragile environment, which is already struggling with global warming and myriad types of pollution. It is because production, transportation and cooking of food lead to greenhouse gas emissions.

Ordering the right quantity of food stock, always storing food correctly, and paying close attention to use-by dates of food to avoid their expiry, having a close watch on portion to be served, can facilitate in reducing food wastage significantly. Ensuring the right temperature control to maintain the shelf life of food, labelling the food correctly, maintaining a stock inventory of food products are other effective measures to prevent food wastage in restaurants.

At the same time, rewarding guests who do not do any food waste (for example by giving them an extra plate of dessert at a much discounted rate as a reward) can also discourage the baneful practice of food waste in restaurants.

Exploring Digital for Guest Satisfaction

The ongoing digital revolution can be creatively used by the restaurants in these trying times to garner more guests through personalised touch. In this digital age, it is much easier as compared to two decades ago for a restaurateur to keep a history of her/his guests' food & beverage

preferences, feedback on what they liked or disliked in the restaurant, and what they would like to improve in the restaurant, on computer (the process can be initiated by letting the guests fill a short form where their F&B preferences and what they liked or disliked in the restaurant and what they would like to improve in the restaurant would be asked for).

This data base can be used to serve the repeat guests to the restaurants better. For example, if the F&B Manager is already informed about the repeat guests' food & beverage preferences she/he can direct the waiter to gently suggest those preferences to repeat guests when they arrive at the outlet. This would help the guests to develop an emotional connect with the food service outlet, which can lead to improvement in revenues for the given outlet concerned in the long-run. This personalised touch can immensely help many restaurants in India especially in these times when many of them are struggling to attain the pre-Covid levels of revenues and growth.

Digital wave can not only enhance guest satisfaction on an individual basis but also guest satisfaction as a whole. If from the data base it is deciphered that more number of guests do not like a particular aspect in a restaurant that can be changed quickly. If more number of guests like a particular aspect of a restaurant that can be retained or even heightened, if feasible. Guests' pragmatic suggestions to improve the restaurant can also be quickly adhered to through digital medium by maintaining a data base of those suggestions.

Succinctly, digital power can facilitate greater involvement of the guests, and this

can be creatively explored upon to garner additional revenues for restaurants.

Edible Cutlery

In these health and environment-conscious times, those restaurants in India's food service industry which offer environmentally-friendly options in their operations are expected to get an extra market edge.

One of the uncommon environmental measures that restaurants can adopt is the usage of edible cutlery. Edible cutlery can not only address the environmental problem inherent in the use of plastic cutlery, but it can be more convenient to use and dispose than their plastic versions, which can easily offset this market advantage of plastic cutlery. You can eat with them and eat them too...And even if you do not want to eat them and dispose them in your stomach then also they can be decomposed within days; not decompose through span of centuries like plastic.

However, it is always preferable to make the edible cutlery with those ingredients whose production doesn't require much water. Otherwise the sustainable edge of edible cutlery would be diminished. If edible cutlery is spruced with healthy ingredients, it can add value to the menu of restaurants in India, especially in these increasingly health conscious times.

Guest Bartender

Involving the interested guests in creating customised cocktails and in wine and food pairing can also be one of the intelligent methods to attract more guests to your outlet. A great many guests would like personal involvement in developing their choice of cocktail with able expert guidance from the concerned bartender/s. Due credit to the guests involved in making their customised cocktail/s can also be acknowledged in the restaurants with urging the other guests to clap to recognise the cocktail making guests. Their guests' role in creating customised cocktails can also be showcased in restaurants' social media platforms.

Here it must be mentioned that adopting one of the above-mentioned measures would probably not lead to quick revival of restaurant business in India but the exercise of a combination of all of these measures has a high probability for quickening the process of an affected restaurant's revival to the pre-Covid levels of revenues and growth. ■





AHAR

THE INTERNATIONAL FOOD & HOSPITALITY FAIR

APRIL 6 7 8 9 10

PRAGATI MAIDAN, NEW DELHI

HALLS 2 3 4 5 (Ground and First Floors)



Safeguards & Represents Interest of Members

HOTREMAI strives to safeguard and represent interest of its members in particular and of the industry in general by taking-up various issues adversely affecting the business of its members with the government bodies, hotels, restaurants and their associations.

Business Promotion

Through its programmes and events: HOTREMAI organizes in-house meets, like Purchase Managers Meet, Hotel Consultants & Architects Meet, F & B Managers Meet, Project & Engineers Meet and such other events, where the representatives of the hospitality industry interact with its members, know their products and services, discuss the problems faced by them and make collective efforts for their effective solutions besides establishing mutual understandings and workout fruitful business deals. This provides its members a platform to demonstrate their products and services and provides opportunity to know their customers' needs.

Special Discounts

For its members, HOTREMAI facilitates with special discounted rates for participating in business exhibitions, fairs, shows and events organized by government and non-government trade and industry promotion bodies

Informative to its Members

HOTREMAI publishes a periodical journal known as 'HOTREMAI REPORTS' in its effort to be more informative to its members and the industry. It carries information on activities, happenings and developments in the hospitality and allied sector and also covers the information on new projects, exhibitions and events. This creates opportunities for members to actively participate by sharing their views and also advertise their products and services at nominal costs. The 'HOTREMAI REPORTS' is circulated free of cost in the hospitality industry.

Different Benefits, One Association !



The Hotel & Restaurant Equipment Manufacturers' Association of India

D-20, Local Shopping Complex, (Upper Ground Floor), New Rajender Nagar, New Delhi 110060.
 Phones : 011-28745698 Mobile : 99100-48121 Email ID : info@hotremai.org Website : www.hotremai.org

Be a proud member of 'HOTREMAI' and enjoy the benefits of being together ...

Red, Juicy and Cool

By Jhuma Biswas

Watermelon is a delicious fruit, which can easily taste more delicious in the scorching Indian summers. According to Wikipedia, watermelon is a scrambling and trailing vine-like plant from the plant family Cucurbitaceae. Its scientific name is *Citrullus lanatus*. Watermelon fruit stems from the flowering plant which traces its origins to West Africa or North-east Africa. In common parlance, one can say that watermelon plant belong to the gourd family.

Tropical to temperate climates are conducive to the growth of watermelon plant. The plant and the fruit are cultivated around the globe. The weight of a watermelon fruit may vary from 1kg to even 90 kg. It is mostly round in shape, but in Japan you can find square watermelons also.

Henceforth, in this article we would refer watermelon in the context of fruit only. The fruit has a rich legacy to match its rich red interiors. However, besides deep red, the flesh of watermelon can also come in pink, orange, yellow or white, though deep red and pink are the usual colours for juicy watermelon flesh, which are dotted with black seeds. Watermelon fruits mostly come with a dark green outer skin.

A Sweet and Rich History

Watermelon has been associated with us since the nascent days of human civilisation. Africa is believed to be the birthplace of watermelons. There is evidence of watermelon cultivation in ancient Egypt, some 4000 years ago. Evidence of watermelon's cultivation can be found from the Nile Valley of second millennium BC. According to Encyclopaedia Britannica, the fruit is depicted in ancient Egyptian art.

How watermelons rolled into India is wrapped in enigma. But there is evidence that watermelons were being cultivated in India during the seventh century, and by the 10th century, this fruit had spread its sweetness to China. The fruit was introduced in Spain by the Moors and there



is evidence of watermelon being cultivated in Cordova in Spain, during the 10th century. The fruit attracted wide cultivation in Europe during the 17th century.

Slowly, thanks to the European colonists and African slaves, the fruit was introduced to the other side of the Atlantic. By the late 16th century, watermelons had arrived in the US and it came to South America in the 17th century. By the mid 17th century it was being cultivated in Peru and Brazil.

Seedless watermelons, which were initially developed in 1939 by Japanese scientists, have become quite popular in the present century.

Production and Cultivation

Today China is by far the largest producer of watermelons in the world. According to

FAOSTAT (Food and Agriculture Organization Corporate Statistical Database), China produced 60.9 million tonnes of watermelon during 2019. According to FAOSTAT, China was followed by Turkey, India, Brazil and Algeria respectively, in watermelon production during 2019. FAOSTAT stated that China accounted for 67 percent of the total watermelon production in the world, during 2017.

In India, the states of Uttar Pradesh, Karnataka, Orissa, West Bengal, Tamil Nadu, Andhra Pradesh and Maharashtra are among the major producers of watermelons. Madhya Pradesh, Chhattisgarh, Himachal Pradesh, Rajasthan, Gujarat, Punjab, Assam and Haryana also grow watermelons. In India, watermelon generally comes into season during the summer months.

Watermelon cultivation requires temperatures higher than 25 degree centigrade to grow well. A well-drained sandy loam soil spruced with organic matter and a pH range between 6.5 - 7.5 are just right for watermelon cultivation.

Delectable Applications

Watermelons have several F&B applications. They are consumed in raw or as salad. Chilled watermelon juice can come as a refreshing drink in the scorching summers fast approaching us. Though watermelon shake and watermelon smoothies are not so common, but they are no less delicious.

Watermelons can be used to make cakes. Watermelon cake, if made rightly, can be a delicious evening snack, particularly in summer days. Watermelon ice-cream can also be a delicious treat in the hot and sultry days. And if you can put some papaya sauce in it then it can taste simply ethereal.

And watermelon can also be used to make delicious breads. Our bakeries should strive to make watermelon breads a tasty, innovative and healthy addition to more and more breakfast tables. I am quite sure such an endeavour of theirs would garner much popularity across urban middle and



upper class India.

Watermelon juice can also be made into wine. In China and Vietnam, watermelon seeds are partaken during the New Year celebrations. Watermelon rind is used to make pickles.

Healthy Fruit

Watermelon is enriched with several health benefits. The fruit is enriched with good quantity of vitamin A and C, calcium, fibre, magnesium and potassium. Intake of watermelon on a regular basis can facilitate a healthy life.

Its impressive potassium and calcium content can facilitate flushing out the toxic depositions in kidney. Moreover, as watermelon has high water content (close to 92 percent), intake of watermelon can facilitate urination, which again is a helpful measure to clean kidneys. So, regular intake of watermelon can help to keep your kidneys healthy. But if you have a kidney disease already, do exercise caution in consuming watermelon.

The lycopene in watermelon, which gives its red colour flesh, is good for your eyes.



At the same time, it does promote heart health. The significant amount of potassium and magnesium present in watermelon can also be helpful in reducing blood pressure.

What is more, the fruit is endowed with anticancer properties. Watermelon has significant level of lycopene, which is associated with cancer prevention. Lycopene has the potential to lower the

risks of prostate, breast, lung, colon, and endometrial cancer. Besides having a good source of antioxidants, watermelons can facilitate to combat the formation of free radicals, which are cause of cancer. Also antioxidants present in watermelons can reduce signs of premature ageing like wrinkles.

As watermelon is endowed with impressive water and fiber content, its regular intake helps to keep constipation away and promote a healthy digestive tract.

Watermelon can be a healthy fruit for diabetic patients as its intake can keep the diabetes in check. Arginine, which is found in watermelons, can be very helpful in increasing the impact of insulin on blood sugar.

So we can see that more extensive and imaginative usage of watermelon has great marketing potential in India’s food service and food retail industry with its increasing numbers of health conscious consumers. It is about time our F&B Managers, Chefs and bakers introduce more creative usage of watermelon in their gastronomic endeavours. ■



Ideal Partners for Planning Commercial Kitchen



All Day Dining, The Connaught by IHCL SeleQtions

Facilities Consultants for:
Hotels & Resorts ★ Hospitals ★ Breweries, Clubs & Restaurants ★ Corporate & Institutional Kitchens

Caterdesign Consultants LLP
(formerly HotelConsult Orient)

10 F, Gopala Tower 25, Rajendra Place, New Delhi-110008, Phone: 91-11- 45061744
Mobile: +91 7042320053 Email: sales@caterdesign.in



The role of condiments in the food service industry cannot be overemphasised. Though their definition may vary, with some definitions of condiments even including herbs and spices in the ambit of condiments, but about their importance there is hardly any dispute. Though condiments in themselves are seldom partaken, but they play huge roles in adding value to the quality of dining experience. Mustard, tomato ketchup and mayonnaise are some of the important condiments which are playing a significant role in our food service industry.

The condiments add to the taste of the food, often in crucial ways. Condiments can be added prior to serving, or during cooking. They can also be had while having food. The example of the first is a sandwich made with ketchup or mustard where ketchup and mustard serve as condiments. Barbecue sauce and soy sauce are examples of usage of condiments during cooking process. The apt example of the usage of condiment during eating is the use of sauce while having omelette during breakfast.

“Nowadays, globally the quality of condiments has become an expression of the quality of a food service operator,” stated Akshay Bector, Chairman & Managing Director, Cremica Food Industries Limited.

The company is an important player in the Indian condiments business. Cremica Food Industries Limited is a part of Cremica Group. The product profile of Cremica includes Indian gravies /curries, tomato ketchup, sauces, bread spreads, mayonnaise, syrups, toppings, salad dressings and Indian snacks, fruit & flavoured syrups among others.

“We are finding that with changing lifestyles, and with increase in income levels in select but sizeable pockets of middle class India there has been a big increase in consumption of condiments and growth of the food services sector in the country. This market environment helps in familiarising customers about new types of products in the realm of condiments and



is helping innovative companies like us to introduce new condiments in the market,” asserted Bector.

Growth in Demand

According to a research, The Indian condiments market stood at \$638.96 million in 2018 and is projected to grow at a CAGR of over 13%, to reach \$1340.5 million by 2024. Anticipated growth in the market can be attributed to increasing cross-cultural interaction, inclination towards consumption of western food & cuisines and growing number of modern retail outlets offering price and convenience advantages to the customers.

No wonder the Indian condiments market is showing impressive growth. The Indian ketchup market has increased exponentially during the last few years. The Indian ketchup and sauce market is dominated by tomato ketchup and tomato sauces. Mustard sauce is also gaining quick popularity. New flavours like mustard and barbeques are widely accepted across nation and marketers are experimenting with the product sizes and convenience packing to increase penetration.

The deep penetration of international dishes like pastas and other noodles has boosted the regular consumption of sauces

and ketchups across all ages. And this trend is only expected to gather momentum in the years to come. In fact, the entire condiments segment is slated for a bright future in the Indian food service industry. Bector confidently projected that “In the next few years, the Indian middle classes would rely on food service industry in a very big way.” With nuclear families on the rise coupled with fast-paced lifestyles, people in India are expected to rely more on appetising snacking options in QSRs and other eating out outlets, in the years to come. This in turn would give a fillip to the condiments business in the country, as it is difficult to conceive a delicious burger or a pizza or even a samosa without the appropriate condiment to complement it.

This is the demand side of the story. There is a supply side of the story too. Another reason for the growth of the condiments business in the country could be accounted by the impressive processed fruits and vegetables market in India, which is also very buoyant. The key categories under processed F&V include jams, jellies, juices, sauces and ketchups.

Especially the demand for processed tomato products like tomato paste, tomato puree, tomato ketchup and tomato sauces is expected to considerably enhance in the country due to the changing eating habits of younger consumers with increasing disposable incomes.

However, it would be simplistic to assume that the growth in the condiments business in India would be largely propelled by tomato ketchup. “The sandwich market in urban India is expected to expand very fast,” concurred Bector. This in turn indicates a better scenario for the mayonnaise and mustard sales in the country, in the near future.

Local Preferences

But new entrants in the food service industry should bear in mind that not every condiment is suitable for every kind of food. Condiments should be intelligently matched with the dishes served.

Besides that the condiments’ usage by the food service establishments in India should take into account of the local preferences. “Condiment has to complement the product and also the local preferences to become a success with the guests, especially in India,” affirmed Bector. The corporate honcho feels that despite the waves of globalisation, local cuisine-based food service is expected to do very well in the Indian market and this entails that



Akshay Bector

it would be pragmatic for the condiments manufacturer in India to tailor and market many of their condiment products according to varied local preferences. “If we produce condiments while keeping the local preferences in mind, the market for condiments in India is expected to only grow,” explained Bector.

Product and Innovation

Presently, the quality of tomato ketchup is a matter of concern with carrot and pumpkin adulteration being rampant. Still a great number of operators in the unorganised food service sector in the country largely depend on homemade ketchups & sauces, where standardisation in quality is always a suspect. However, compromise in ketchup quality is not only limited to the unorganised food service sector in India.

But the food service outlets, especially the high-end food service outlets in the country must realise that the quality of condiments are expected to play an even more important role in the Indian food service business, as the consumers are getting more and more discerning.

As the market for condiments business in India gets hotter, more and more players are expected to enter the segment. This will give the discerning segment of Indian consumers (whose numbers are increasing) more choices in terms of condiments and many of them are unlikely to settle for inferior quality of condiments. Thus quality and innovation will be key factors to create a long-term business in the Indian condiments market. In this regard, Bector feels that they have an edge in the market. “Cremica is known for product innovations and for offering customised and localised food products to the consumers. We are trying

to offer as natural products as possible to our customers,” he offered.

In this regard, the entrepreneur stated that they had introduced the improved versions of Sandwich Mayo range in the retail market as well as across the food service industry, which have been developed to be grill stable. They come in flavours specially suited for the Indian market. The flavours for this sandwich mayo range include chipotle, cheese, korma, tandoori, mint, pickle tickle among others. “Besides this the improved version of our already world class salad dressing range was introduced to cater to the discerning demand in both retail and food service category. The improved versions of Salad Dressing is available in five flavours i.e. Caesar, Russian, Italian, Thousand Island and Vinaigrette,” he added further.

Moreover, increased focus on R&D activities in the food industry has brought various development in food quality and innovations in products such as sugar-free and gluten free condiments which is stimulating the trend of healthy living. This factor is expected to provide ample opportunities for the condiments market by 2024. Additionally, emergence of diet sauces and other condiments is also expected to fuel growth in the market. Furthermore, increasing standards of living, changing lifestyle and rising demand for sophisticated taste in meal are emerging trends in the industry.

Quality Matters

A marked upward shift in the quality of condiments can facilitate in enhancing restaurants’ business. “The difference in price between a high quality condiment and an average quality condiment may not be much, but the difference in the restaurant’s revenues that the marked difference in the quality of condiments can accrue significantly in the long-run, especially if viewed in the context of the fast evolving Indian food service industry,” explained Bector further.

Moreover, he thinks that purchasing high quality tomato ketchup is expected to save money for the buyer in the long-run (though having high quality tomato ketchup may apparently seem to be a slightly costly proposition in the immediate future) as consumers tend to feel satiated by using a much smaller quantity of high quality tomato rich ketchup than what they would be needing if the ketchup is diluted in terms of its infusion of tomatoes. ■

A Dreamer & Hospitality Wizard!

Rajan Sethi, Entrepreneur, Restaurateur, Founder - Bright Hospitality Pvt. Ltd.

Born in a liberal Sikh family, Rajan Sethi has always been a dreamer. After completing his graduation, he had the option of joining his father's electronics business but he chose to go to Sydney, Australia to study in 1999. Armed with an MBA in International Business from Macquarie University, he joined the family business as a management trainee and went on to become the Director, Marketing. However his heart yearned to step into an uncharted territory.

In 2007, he set up Bright Hospitality Pvt. Ltd. with an audacious dream. A dream to revolutionize the hospitality industry. Over the next six years, he set up a range of hospitality outlets in Rajouri Garden namely, The Pind Balluchi, The California Boulevard, AM.PM. and The Eternity. Each venue true to its name is an experiential delight. His latest venture is 'Kung Fu Mamma,' an authentic Pan-Asian delivery brand based in Gurgaon.

He is an avid traveller, a wild life enthusiast and a seasoned mountaineer. His passion is to explore new countries, cultures and cuisines. A professional to the core, he believes in setting gold standards in the world of hospitality. He wants every Indian to savour the flavours of the world and is already dreaming of his next venture.

In an exclusive interview with **Sharmila Chand**, he talks about his brand and more...



Tell us the USP of your brand/restaurant?

Kung Fu Mamma is Bright Hospitality's latest venture and a very special one as this is our first and foremost delivery brand. It is born amidst the pandemic, a passion project with attention to detail in every sphere, from hygiene and food safety to authenticity and sustainable packaging. A mother in an avatar of a versatile Tigress Chef, Kung Fu Mamma is a legendary culinary artist whipping together bowls of love and delectable dishes to satiate all your Pan-Asian cravings. The menu consists of a vast array of Pan-Asian flavours ranging across regional dishes and flavours from across the Asian continent.

Key challenges faced during the launch?

Anyone can start a restaurant but the bigger question is how we set new

standards in the hospitality business. My team and I spend a lot of asking simple yet fundamental questions. The 5 big challenges that we face when we have to open a new restaurant are:

- What do we offer the guest that is different from what is already there in the market?
- What is the concept of the brand/restaurant and how do we do 100% justice to the concept?
- What kind of people do we hire so that our products and services are magical?
- How do we constantly delight the guest from the first 'welcome' to the final 'good-bye'?
- How do we recover our investment, without ever compromising on product quality and finesse?

What helped you the most in launching the brand?

Amidst the pandemic when most established hospitality brands and restaurants were laying off staff and disintegrating teams we at BHPL did the exact opposite and assembled the best of talent that was culled from top institutions and got them together to develop BHPL's first pan Asian brand- Kung Fu Mamma. Bringing together people who shared the same vision really helped us birth Kung Fu Mamma as a passion project, close to all of our hearts.

What are the major issues faced by hospitality/food business today?

The consumer today is far more discerning and demanding. They are willing to experience, experiment, explore new cuisines and flavors of the world. The big issues for any hospitality and food biz are as follows:

- Understanding the fussy Indian palate and providing a great authentic experience
- Getting trained / skilled professionals to deliver an outstanding product and service
- Maintaining a high level of hygiene at the backend
- Balancing taste and nutrition without compromising on either
- Getting the price-value equation right
- Going beyond vanilla offering
- Providing an outstanding dining/delivery experience

With your experience, how the food trend has changed over a period of time?

Keeping up with the times is the backbone of all great inventions. The year 2020 brought a revolutionary change in all of our lives. The focus of today's consumer has shifted from taste and junk to nutritious, clean and healthy food.

What has contributed in image building of your brand?

We believe that a delicious plate on the table is the best advertisement in our business. When our guests talk of their memorable experiences with us, it becomes the best PR in the world. We don't believe in big ad budgets but are big hearted on outstanding service. Today consumers are digitally savvy and they speak their heart on social networks. Rather than speaking about ourselves, we allow our guests to talk about their experiences with our brands. It is far more credible and honest. We do a bit of cross-selling via our portfolio of brands and keep inviting guests to a range of festivities and events that we host at all our restaurants.

What inspired you to launch this brand?

It was my team's and my love for authentic Asian delicacies and lack of their presence in the Delhi NCR market (specially for delivery) that helped us lay down the inception stone for Kung Fu Mamma. It has been a devoted team effort ever since for all of us to revive authentic, local Pan-Asian recipes from remote regions of the continent and bring them to our patrons as an epitome of food revival. This has been a particularly dangerous territory for us to venture into keeping in mind the preferences of the Indian market when it comes to the "Indian Chinese" palate. However, the experience has been nothing less than rewarding since our food has been highly appreciated by all our customers.

What do you enjoy most about being in this business?

India is slowly waking to the reality that great service is part of our cultural DNA. Our company is driven by a simple belief, 'Athithi Devo Bhava' - Guest is god. We

believe that 'if it is right for the guest, it is right for our business'. Our product and services are evaluated every minute by our guests. We cannot afford to let our guard down. What I love most about our biz is that it gives us an opportunity to serve.

Further, this business generates a lot of positive energy around. Unlike other businesses where competition means reducing the MRP of the product, in the hospitality business, competition means bringing the best product & service on the guest's platter. So all our energies are consumed towards betterment, rather than price-cutting, that brings a lot of positivity in our endeavors.

What kind of pressures have you encountered at work?

- Getting outstanding reviews and feedback from guests
- Launching new foods / beverages that no other restaurants serves
- Leading a well motivated team at the workplace
- Ensuring optimum table occupancy
- Connecting with the digitally savvy new generation

What are your future plans to expand your brand?

At BHPL we want to create a chain of experiential delights across the country. We are clear that until and unless we have a powerful concept, we will not open another restaurant and/or delivery brand. We're currently toying with a dozen ideas and we hope to convert at least half of them into reality in the next 3 years.

Anything you would like to talk more about your brand?

We at Kung Fu Mamma take a lot of pride in using 100% conscious packaging thereby reducing our carbon footprint. The outer packaging used for food deliveries is 100% recyclable, biodegradable and eco friendly. The base box used is made up of 4 ply, e-flute corrugated material which is made up of semi-craft, that is, it is made using recycled paper and sugarcane waste. The top of the boxes is made using SBS which is also an eco friendly material. Further, we use jute strings to secure the boxes which are locally sourced and 100% recyclable.



Passionate *and* Methodical!

Anuj Kapoor, Consultant Chef

Chef Anuj Kapoor develops and executes Food and Beverage concepts for premium restaurants and hotels. His latest project is one of its kind concept of temple foods of India at 'Varr' Restaurant located at Holywater by Ganga Kinare, Rishikesh.

Chef Kapoor holds rich experience having worked as the Corporate Chef for Compass Group PLC and Four Points by Sheraton in India, Executive Chef of The Grand, New Delhi & Azaya Beach Resort Goa. He has launched & operated some of the most reputed F&B brands in India and abroad such as Olive Bar & Kitchen, Olive Beach, Set'z (Zest), Yum Yum Tree, Manré, Café Amor, Cha Shi, Café E, Kebab Khan, Zazen and Kink, to name a few. In addition to having a rich background of exemplary culinary experience, he likes to nurture budding talent as well. He has created several programs to mentor numerous aspiring chefs.

In the initial years of his career, he learnt the nuances of authentic Spanish, Mediterranean, Italian & the Middle Eastern cuisines. Later, he ventured into Indian & Pan Asian food.

He graduated from Hotel Management School, IHM Lucknow in 1996 and started his career as Management Trainee at The Park Group of Hotels. He honed his skills through working hard with a wide spectrum of Food & Beverage business ranging from five star properties, fine dining restaurants, hospitals, bistros and casual diners. He has worked in Bangalore, New Delhi, Chennai, Mumbai, Melbourne, Singapore and Dubai. He has also worked with many well renowned Chefs like Greg Malouf, Massimo di Luca, Manu Feildel, Catherine Claringbold, Antonio Carluccio.

In an exclusive interview with **Sharmila Chand**, he talks about his work philosophy and more....

What is your philosophy of cooking?

My Motto in all my kitchens over the years has always been - 'ACE' - Authenticity, Consistency, Eye for Detail.

What is your area of expertise?

Indian food is my native cuisine but surprisingly as a professional Chef - in the beginning of my career it was Spanish cuisine - I was trained under Spanish Chef and was the Chef in-charge of the first Spanish restaurant in the country (Las Meninas). Later I delved into Italian cuisine, and then grew the specialty to Mediterranean. I was lucky that I got to work with some of the finest international chefs of various countries and picked up those cuisines from the best masters available at the time. Greg Malouf (Mid Eastern cuisine), Massimo di Luca (Italian), Catherine Claringbold (Australian), Manu Fieldel (South American). But those were the initial years. Thereafter, I have got the opportunity to return to the roots and opened and operated multiple Indian F&B concepts.

Tell us about your latest work?

My latest work has been curating the concept of Varr Restaurant at HolyWater by Ganga Kinare, Rishikesh. It took us over three months of extensive research across temples of India and the Bhogs offered to deities and Prasadam distributed in and around the temples.

Since Ganga Kinare has a multi cuisine restaurant called Jal&Jalebi, we wanted another speciality restaurant which would deliver a unique cultural experience to our guests and take them back a thousand years. Temple food was something which did not have its presence anywhere in India, let alone Rishikesh. With this thought process we launched VARR which would offer a thousand year old history of Indian temples on a plate and would

leave our guests with a story to tell and a deeply spiritual experience.

The service sequence, audio visuals and small rituals at VARR will fill Indian as well as international guests with great respect towards our culture and that is something we wanted to aim for while serving some extremely fantastic food cooked with healthy ingredients, sourced locally and from select vendors across India.

Why is this concept important in the New Age?

We believe that the onset of Covid is a great turning point in the history of India as well as the world. In keeping with our belief that we as humankind need to celebrate and respect what we already have and pause this relentless pursuit of material expansion, we felt that the concept of VARR was apt and contextually relevant to explore now more than ever.

There has to be a place for a speciality restaurant like VARR in the Indian landscape which seeks to keep the traditions of our temple food alive and acts as a reminder to our guests of where we come from. Guests who visit us come with the multiple generations of their family together, from 6 to 60 year olds. The amount of inputs that every single guest is giving us apart from just rave reviews is overwhelming and deeply motivating for our team. We feel we have only explored the surface when it comes to temple foods of India and this concept needs to exist even internationally as a flag bearer of Indian traditions in its purest form.

What has been the most rewarding moment in your career?

His Royal Highness, the Prince of Spain had visited India, and one of his dinners was at my Spanish restaurant. I was heading the Paella station (traditional Spanish complex rice preparation, think Biryani). After the dinner the Prince wanted to meet the person who made the Paella. He shook my hand and mentioned -"Your Paella reminded me of my grandmother's Paella, she used to make it exactly like this."

How has the journey been so far?

The journey has seen tremendous amounts of learning, having worked in so many cities and with so many nationalities. For me most important part of being a Chef is that each day is a new day with fresh ideas, learnings and excitement. There's no monotony.

What are your future plans?

Disclaimer - It probably won't sound that Glamorous. I would want to revolutionize Hospital food next. I would be on a lookout for that kind of opportunity. There's really no reason for Hospital food to be sad and boring. And of all places where a person dines - Hospital can be one place, where one would appreciate good food, without the distracting phones & screens, even without the chatter of group of people!



DEPUIS 1885

GIFFARD

SIROPS



PRODUCT OF FRANCE



**VISIT US @
HALL No.4**
STAND NO: 36 (4U-13 F)
FIRST FLOOR

FIFI Pavilion
(Pragati Maidan, New Delhi)



@giffard_india



*Available in 41 Flavours

*Products Are Available On Amazon, Flipkart & Snapdeal.

Distributed by:

Euro Foods Pvt LTD (HO)

546-547, 5th Floor, DLF Tower, Shivaji Marg,
+91-11-4557-9574 / +91-11-4557-9576
New Delhi-110015, INDIA

Euro Foods Pvt LTD (BR.)

No. C/401, 4th Floor, Hyde Park, Saki Vihar Road,
Opp. Ansa Industrial Estate, Andheri (East),
Tel: +91-22-28575629 / +91-22-28575677
Mumbai - 400072, INDIA

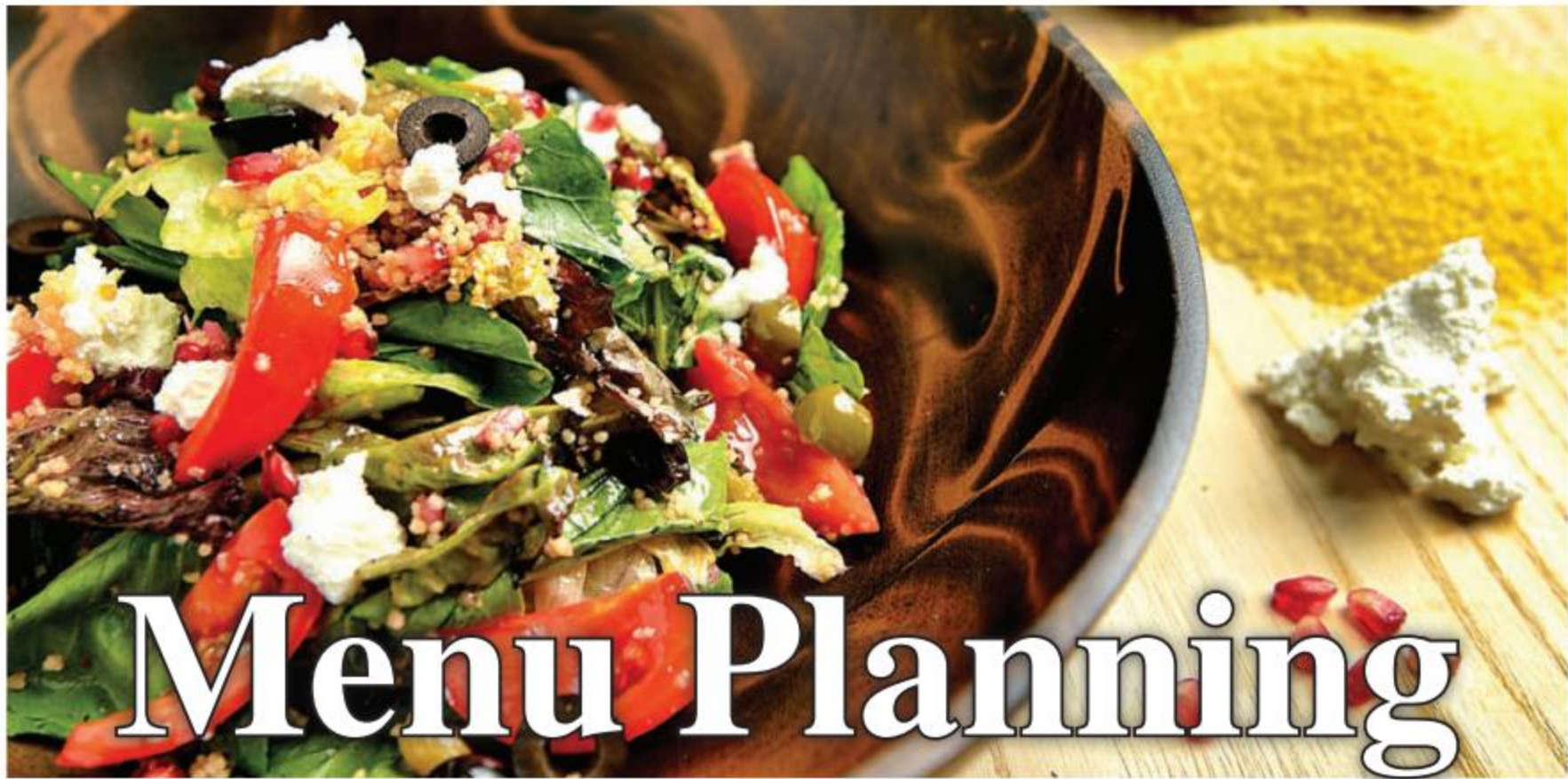

By Sharmila Chand

Curating a perfect menu is as significant as preparing a perfect dish. In food production and operations, planning of menu is a crucial task. Chefs need to give lot of thought in considering several factors before the final menu is presented. Here we talk to chefs and find out what they have to say about their focus in curating the menus and also giving tips that can help organize the food preparation and ensure the food offered is not only tasty but also healthy and nutritious.

Focus in Menu Planning

Amitesh Viridi, Executive Chef, JW Marriott Mussoorie Walnut Grove Resort & Spa

Serve authentic cuisines - With the market opening up to a world of food from our very own regional cuisines like Garhwali, Kumaoni, Parsi, Bengali etc to foods of other regions like Mediterranean, Thai, Japanese etc, there is an emotion amongst everyone to enjoy what each cuisine offers in its own way and not mix up all flavours to create a fusion. People are well travelled and wish to explore the authentic tastes more.

Promote healthy living through mindful eating - Healthy living is on the rise and people are more aware about their bodies, their exercise routines, the foods they should eat or want to eat. There is more focus on gut healthy foods, immune building foods, protein rich foods, carbohydrate,

dietary fiber, probiotics, etc along with an individual's body's intolerance or allergies.

Promote Regional Indian Cuisines - It is always exciting to keep exploring our regional cuisine and brought out in the open. These cuisines are tasty, nutritious and cooked with readily available seasonal produce which our climate supports.

Use of Locally Sourced Ingredients - There are many ingredients in India that are left untouched and unexplored by masses. They are slowly gaining popularity and

developing a strong fan base. Procuring local ingredients is better option because these are well adjusted to local climatic conditions and topography of the place. The yield of these ingredients is much better. Secondly, our bodies are more responsive to digesting the foods that grow around us.

Curating F&B Experiences - I would love to create Chef's Table at exciting locations, think of creative f&b setups, curate personally designed menus and theme based meals experiences.



"The focus in menu planning will be majorly on incorporating more healthy and immunity boosting food and drinks"

Sudershan Bhandari, Executive Chef, Eros Hotel, New Delhi Nehru Place

Chef Nitin Bhardwaj, Corporate Chef, Kampai and Mai Bao

Innovate & Ideate - Menu planning for us will be all about innovation and coming up with new ideas. With Kampai, we are planning a lot of new things in our food as well as cocktail menu. We are also going to be focusing a lot on our new Singaporean restaurant, Mai Bao and put all our efforts in ensuring authenticity in both brands.

Focus On Healthy Food - Healthy modern street food from hygienic kitchen, which one can see in Mai Bao.

Embracing the concept of Pop-ups - Pop-Ups known for innovative cuisine, eclectic locations, and community focus, are expected to start popping up everywhere! These establishments are ideal for restaurateurs post-COVID-19 due to their low overhead and minimal food waste. We have recently managed to do three pop-ups successfully in the luxury residential

"I will introduce several immunity boosting dishes in the menu. Healthy food is the need of the hour"

Ajay Markan, Corporate Chef, Cygnett Hotels & Resorts

properties of DLF and are looking forward to exploring more this year.

Around the World on a Plate - We know that food isn't strictly about substance. It can create feelings of nostalgia and evoke emotional responses. Cuisine can connect us to our families, communities, and to cultures around the world. A restaurant trend we are sure to see is a focus on global cuisine. We might not be able to physically journey abroad by plane, but we can travel via the plate. Connection and comfort can be expressed through global-inspired dishes that tell a story. With Kampai & Mai Bao, we promise to export you to the beautiful cities of Japan & Singapore respectively.

Chef Anas Qureshi, Brand Corporate Chef- Molecule Air Bar

My major focus will be around using seasonal locally sourced products and ingredients with natural health benefits, incorporating immunity boosting dishes in the menu.

Comfort food will also have a major part to play in my menus. I am looking forward to creating more nostalgic flavours, indulge in heritage cooking and not so complex recipes. My menus will be short and crisp reducing wastage and spoilage.

Take away menus will also have equal importance as a la carte menus with great verities and new techniques that will give the guests a unique dining experience in the comfort of their home.

Ashish Singh, Corporate Chef, Cafe Delhi Heights

Balanced Nutrients - My focus will be on creating balanced meals with proper hygiene care. We need to serve good food to lift the mood. A lot of emphasis will be on including immunity enhancing dishes in

"Serve a menu where each dish is a Superstar"

Amitesh Virdi, Executive Chef, JW Marriott Mussoorie Walnut Grove Resort & Spa



"2021 is going to be a comeback year for the hospitality industry and we need to ensure that the customers get to choose from a healthy and sustainable menu"

Ashish Singh, Corporate Chef, Cafe Delhi Heights

the menu. The seasonal produce will be kept in mind while curating the menu.

Sustainable and Organic food options - Diners are increasingly making a switch to foods that match their changing values and desire for more sustainable and healthy options so the menu needs to be designed accordingly.

Chef Harangad Singh, Chef & Founder - Parat

My focus will be on structuring



"Menu should have interesting dishes that catches everyone's attention, something new that probably has not been experienced at any other place"

Chef Anas Qureshi, Brand Corporate Chef- Molecule Air Bar

"The concept of 'vocal for local' will be in the forefront for us when we plan the menu"

Janti Dugal, Food Director, Azure Hospitality

the menu where you have something for everyone.

Second thought is how to create a menu which touches you through a nostalgic emotion.

Third is to ensure to create the menu around the availability of local ingredients.

Ajay Markan, Corporate Chef, Cygnett Hotels & Resorts

My focus in menu planning will be regional & local cuisine bursting with flavour and freshness with locally grown produce and ingredients. Let diners enjoy the local cuisines, the seasonal goodness that it brings and also, I believe, when in peril people go for comfort food and regional food is comfort food.

Altamsh Patel, Executive Chef | F&B Production, Oakwood Premier Prestige Bangalore

Those days are gone when guest use to feel good by looking at the menu card with 150 to 200 dishes. The new mantra is a 'more focused' menu. We will focus on making a smaller limited menu with maximum 35 to 40 signature dishes in it with all the dishes having some history behind. I will also try and mention the source of ingredients so that the diners have clear idea about what they are having. Importance will be given to seasonal ingredients and wherever possible will try and use locally produced ingredients in our dishes."

Janti Dugal, Food Director, Azure Hospitality

The concept of 'vocal for local' will be in the forefront for us when we plan the menu. During the lockdown, we discovered a lot of homegrown brands and interesting new products that are available in India. We have discovered cheese producers, smoked meats etc that have given us a lot of options in terms of buying local and showcasing Indian ingredients in the best manner. As the industry is also in recovery mode, this is a more budget-friendly as well



"My mantra is a 'more focused' menu with limited signature dishes having some history behind and using locally produced ingredients wherever possible."

Altamsh Patel, Executive Chef, F&B Production, Oakwood Premier Prestige Bangalore



"We ensure you put 5 star dishes which will define the personality of the restaurant. 20 dishes which you will put in the category of horse which are regulars and will generate you finance as they will be the fastest moving and public friendly food dishes. 10 dishes which you will keep experimental which you will put in the category of puzzle and change it more frequently if it does not move."

Chef Harangad Singh, Chef & Founder – Parat

as a cleaner, safer approach, so reliance on imported goods is going down and keeping this in the focus, we will be planning our 2021 menu.

Tips for Menu Planning

Amitesh Viridi, Executive Chef, JW Marriott Mussoorie Walnut Grove Resort & Spa

- We focus on the targeted customer base and their requirements. Menus are then made based on the current trends in the market and price load for per person in this segment. There are certain markets that are price conscious, so we thoroughly explore and understand the local emotion of the area and deliver the menu within those boundaries.

- Cost of food, staff skill set and other expenses are also a strong factor while curating menus.

- When we target families, foods for children are very important and recipes are well researched. We make sure that children are looked after well, their food looks prettier and taste is as per their preference.

- A good balance of dietary preferences – protein, carbohydrates, fiber rich, gluten free etc are all kept in mind to prepare a well-balanced menu

- Ingredient availability to the area within reasonable prices by local markets is a deciding factor.

Chef Nitin Bhardwaj, Corporate Chef, Kampai and Mai Bao

We ensure that the dishes we plan for our menu based on market, location, cuisine, local, easily available, healthy full of nutrition value.

- Cost effective
- Seasonal
- Tasty
- Organic and from hygienic friendly environment

Chef Anas Qureshi, Brand Corporate Chef-Molecule Air Bar

Work on the lines of the concept of the place, the menu should be in sync with the theme of the place.

Menu should be balanced with multiple flavour options so that every guest has a dish to choose from the menu according to his/her taste.

Ashish Singh, Corporate Chef, Cafe Delhi Heights



"Choose your food wisely; it should be healthy and tasty"

Chef Nitin Bhardwaj, Corporate Chef, Kampai and Mai Bao

- Incorporate seasonal produce for better taste and affordability

- Balancing the number of unique ingredients in the menu to control costs.

- Minimise wastage

- Time management -planning the menu in such a way that food service is on time.

Sudershan Bhandari, Executive Chef, Eros Hotel New Delhi Nehru Place

"Truth in Menu" also referred to as "Accuracy in Menu" is a best practice in planning and sharing menus. In general, Accuracy in menus addresses any and all of the following:

Variety - Now a days, guest are looking for healthy variety in menu, so they can enjoy every bit of their meal as guest around the world are getting more conscious of their health.

Quality - 2021 will be more about quality in terms of using best ingredients with hygiene as people are more health and hygiene conscious than ever before.

Balance (calorie) - Another best practice is understand the calories balance. Special meals like vegan, gluten free, will be trending in menu.

Food Preparation - Now guests are more conscious about how their food is being prepared. They want to know what kind of raw materials are being used, what safety and hygiene standards are being used while cooking etc. Here, chefs interacting with guests as to what best efforts are being put into preparing their food is highly recommended.

Modern Presentation - Another notable aspect is the food presentation which is simple yet attractive and eye-appealing.



Invites Participation
in the 36th edition of
Aahar 2021

45%
Reduced
Tariff than
last Year



Product Displays

- Food & Beverages • Processed Food • Food Ingredients
- Food Processing Equipment. • Packaging Machinery
- Restaurant & Kitchen Equipment • Cleaning & Hygiene • Interior & Furniture
- Hotel Design • Bakery Equipment & Supplies

ARCHII is well recognized platform to discuss the possible arrangements, contracts, dealings between member's interest to regulate and standardize as far as ethical business practice in the hospitality trade.

ARCHII arranges, sponsors and support various conferences, exhibitions. It promotes goods/equipments by arranging meeting and one to one discussions with multiple invited high profile visitors and guests.

ARCHII has been actively involved with ITPO to organise Culinary Show & Seminars at previous edition of Aahar

For Space Bookings & Good Location, Contact : Mr. Vijay (Sec.)- 9506315924, Ms. Bharti (Ex. Sec)- 9871582149

Association of Resource Companies For the Hospitality Industry of India

LB 2/2, Manu Apartments, Mayur Vihar, Phase-1 New Delhi-110091

E-mail: archii.association2020@gmail.com | archii.association@gmail.com

Website: www.archii.org



An Ode To Temple Food Of India ! Prasadam at Varr



By Sharmila Chand

In the holy city of Rishikesh, guests have a spectacular fine dining destination, Varr, offering the 'Temple Cuisine' served in the temples across India. Located at Holywater by Ganga Kinare, 'Varr' takes you on the journey of pious offerings to deities from Pathar Sahib, Ladhakh to Sree Padmanabhaswamy, Thiruvananthapuram. From Jyothirlinga of Somnath, Gujarat to Govindev Jee temple of Manipur and more.

WOW Concept

The food is based on principles of Authenticity, Ayurveda, Seasonal, Local and Healthy Ingredients.

Every dish of the bhog or prasadam at Varr speaks of the painstaking efforts made by the team in terms of the research done to ensure the authenticity of the cuisine. Several trips were made by the team to all the regions to understand the sacred food ingredients, preparations and gathering tips from the locals of that region.

Hence, the chefs at Varr take pride in offering everything from Pavakkai Pitlai, a bitter gourd curry and Puzukhu made from ripe jack fruit and black chanas, to Mangai ko Samalli, the brinjal gravy dish and Javarisi Paal Payasam, made from sago and reduced

milk, served across temples in South India and Bhoger Khichuri from Orissa to Langar di Dal of Golden Temple, Amritsar and the Poori Chana of Vaishno Devi.

Ingredients play a vital role and one can see how careful they have been in procuring these to ensure that the ingredients used are true to the temple of the region.

Menu keeps changing according to the season, ensuring to use local and seasonal produce. Selection of ingredients are based on principles and wisdom of Ayurveda and inspired from traditional practices across Indian temples. Also there is a generous infusion of immunity boosting ingredients such as Cinnamon, Curry leaves, Tulsi, Ashvagandha, Giloy, Triphala, Gooseberry, Ginger, Nutmeg, Turmeric, etc. in the preparations.

Menu Planning

At VARR, diners are taken on a culinary pilgrimage of the best known prasadam from temples across the country. It comes in the form of well curated thalis conjured up by the award-winning chef Anuj Kapoor. The inspiration comes from all regions including Gurudwaras, the Himalayan Char Dhams, Brijbhoomi, Sri Padmanabha Swami,

Thiruvananthapuram; Akshhardham Temple of Vadatal, Gujarat, to Jagannath Temple Puri, to name a few.

About 36 unique dishes are served course by course in every thali and the menu keeps changing for lunch and dinner both every day. There is a set theme to let the guests discover the variety of delicacies that are served in temples of a particular region. Meenakashi temple's Puttu, Pokharo at Jagannath Puri temple, Ringan Nu Shaak at Dwarka temple or Annakoot and Besani Poori at Vrindavan, Kada Parshad at the Golden Temple in Amritsar... and so on.

Every Meal starts with 'Holywater Panchamrit' -

Abhisheka Prasad made of cow milk, ghee, honey, Ganga jal and tulsi (holy basil). Followed by Suswaagam-

Welcome Drink 'DhwaanChaas' - signature welcome buttermilk drink smoked with ghee and sizzling coal. Then appetizers are served which are outstanding. 'Panira Bhatta' is one of the signature appetizers - fresh cottage cheese marinated in lemon juice is coated with spices made of coriander, freshly grated coconut and mustard seeds, wrapped in banana leaves and cooked for

a few minutes till the flavours fuse. The inspiration of Panira Bhappa comes from Lord Jagannath Temple in Orissa.

There is an unparalleled treat in the mains with special dishes including Kadi Pakoda, Barsaane ki Arbi, Nadru, Jagannath Namak Khichidi, Kozhambu, Payasam and Poriyal, each dish inspired from a specific temple of India. There is also Seetaphal Khatte Meethe - tart, sweet and pleasantly bitter all at once, this pumpkin preparation is a popular accompaniment to fried pooris/bedhmi. Vegetable Stew is prepared with coconut milk and vegetables mildly scented with whole spices - bay leaf, clove, cinnamon and black pepper corn.

Curries and Dal

Curries are eclectic choices with varied flavours like 'Urad Dal Vadi aur Aloo'- potato and dry lentil dumpling (vadi) cooked with Indian Spices. 'Paneer Tamatar Wala' - Clay oven roasted fresh cottage cheese served in whole spice infused rich tomato gravy from Bade Mandir in Delhi. 'Pahari Palak'- wild spinach cooked in mustard oil tempered with jakhiya, a local delicacy from Garhwal. 'Bade Mandir ki Urad Channe Dal' - rich creamy lentil preparation using sendha namak (Himalayan Pink Rock Salt) without onion and garlic. 'Vaishno devi Ke Channe' - a delicate and wholesome preparation using black gram, tempered with cumin, freshly chopped ginger and Indian spices, this dish is offered as Bhog and distributed among pilgrims as Prasad in Vaishnodevi's abode at Trikuta Hills in Katra.

Masala Carrot, Bean, Cabbage 'Poriyal'- Stir fried shredded or diced vegetables along with spices and grated coconut from the temples of South India. 'Methi Palak Bathua Saag' - Tempered with mustard, this North Indian preparation of stir-fried chopped green leaves of fresh fenugreek, spinach and bathua is much in demand.

'Dalma' : an all-in-one dish with lentils, vegetables and spices, is very special.

Rice Preparations

Rice preparations once again, perfectly encapsulates Varr's philosophy of serving dishes that are inspired by the prasadam of temples across India.

'Thakkali Sadam' - is the tomato rice made with par boiled rice, tomato paste, tempered with mustard and curry leaves. Thakkali Sadam finds its reference in Tamil Sangam Literature as one of the dishes served to deities during festive occasions. 'Matar Ki Tehri' is flavoursome, inspired



from Raj Bhog to Goddess Annapurna and Kashivishwanth during the Annakut festival in Varanasi.

'Braj bhomi ki Khichdi' - is aromatic rice and channa dal preparation, an integral part of BhogPrasada at Krishna Temples. 'Udupi Curry Rice' is served beautifully with a delectable curry paste wrapped and steamed inside a banana leaf, a culinary delight that dates back to the 13th century from the temple town of Udupi. 'Swaminarayan Khichdhi' recipe comes from Gujarat and entices you sufficiently.

Interesting Flat Breads

There is a beautiful combination of Rotis, Choorika Parthas, Bejarki Roti, Appams, Radha Vallav Bedmi, and not to forget, NagoriPuri - an all-time favourite small bite size poori, famous from the streets of Chandni Chowk in Delhi. There is also 'Ragi Idli', Ragi Dosa, 'Chane aur Jauki Roti', and

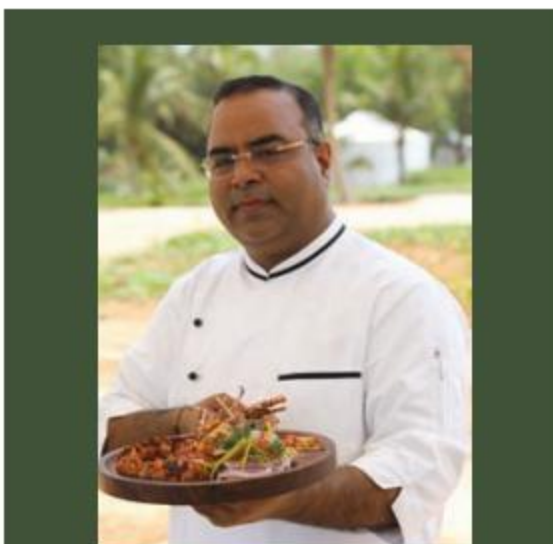

"The food served at Varr is inspired from Temples of India. All our preparations are done in pure Desi Ghee and infused with immunity boosting Ayurvedic herbs and spices. We are happy to have created a complete fine dining destination where diners are taken on a culinary pilgrimage of the best known prasadam from temples across the country"

Chef Anuj Kapoor, Curator of Varr Concept

'Methi Bedmi' - each with its own Prasadam inspiration.

Sangatmein

Relish your meal with exhaustive list of condiments (Sangatmein) which are truly the exciting part of the menu. These include variety of pickles, murabbas, mint chutney, Krishna Chakri (Pappadams), Dahiwada, and Pallar. 'Pallar' is a delicious smoky, locally spiced, fermented butter milk from the valleys of Uttarakhand. Traditionally served during festivals, this drink also aids the digestive system.

My favourite was 'Delaka Achar'- Tenti fruit pickle which is not found easily, earthy 'Baas Ka Achar' - Bamboo shoot Pickle and 'Kale tilki Chutney' - Chutney made with roasted black sesame seeds and lemon juice - a local delicacy from Gharwal.

Alluring Beverages

Deeply satiating and nutritious beverages infused with seasonal flavours are intrinsic part of the menu. Enjoy 'Karbooje Ka Panna' - Muskmelon pulp and juice are flavoured with saffron and cardamom, sweetened with rock candy sugar and mixed with cold water to make a delightful refreshing beverage. Do not miss 'Pudina Jal Jeera' - a refreshing beverage flavoured with cumin and mint.

Desserts (Meetha Prasad)

Savour a plethora of sumptuous desserts, once again reminiscence of prasadam from various temples. 'Kadha Prasad' is a type of whole wheat flour halva made with equal portions of whole-wheat flour, clarified butter, and sugar. 'Chatursugandh Coconut Payasam' - Coconut milk is slowly simmered with cardamon, clove, cinnamon and edible camphor. 'Mathura ke Pedhe', Imarti Rabri, Rice Kheer, Sondesh, Mohanthal - a mishtan which is said to have been loved by Lord Krishna - are delicious to end the meal on a sweet note!

Step in at Varr and be prepared to get a very warm welcome to create lasting dining memories. The bright and cheerful décor enhanced with aromatic incense, soothing chants, temple musical instruments as artefacts all around are spectacular to uplift your mood and spirits. Once you settle down, the team starts serving the food which is heart-warming and will wow your palate. There can be no better place to head to, than 'Varr' if you have the desire to relish a melange of flavours and textures from the Temple Cuisine of India. This is an experience you owe yourself! ■

What is on my Table?

To ensure the supply of ever growing demand for varied food products by consumers, the stores are now stocking much wider range of products than ever before. With the greater awareness among consumers to differentiate paleo from keto, and vegetarian or organic products, healthy ingredients, culinary experts are constantly innovating cuisine to satisfy their palate.

But the multiplicity of choices and explosion of information has led the modern consumer to face a serious dilemma of food traceability. One simply doesn't know where the food comes from. Consumers have become just as interested about what's printed outside the package, as are about what's inside it. Food packaging labels are not just about manufacturing & expiry date, they're covered in fine print that attempts to tell little bit more about what one is about to consume.

Food Traceability

Food traceability helps in understanding the movement of a food product and its ingredients through all steps in the supply chain, both backward and forward. Traceability involves documenting and linking the production, processing, and distribution chain of food products and ingredients. Food traceability is defined as the highest possibility of historical tracking of food products such as raw and semi finished items which are able to ensure all the finished products are safe for consumption.

If there is any untoward incident involving food like foodborne illness outbreak or contamination event, efficient product tracing helps agencies and those who produce and sell food to rapidly find the source of the product and where contamination may have occurred. This enables faster removal of the affected product from the marketplace,

reducing incidences of foodborne illnesses.

Thus vendor-neutral technologies & open standards that allow track & trace across food supply chains are required to be adopted by food businesses to mitigate risks and undertake effective product recalls.

Ensure Food Safety

With rising incidences of unsafe food in global supply chains, food safety has become critical for both businesses and consumers. Worldwide, the role of traceability as a means of enabling food safety is being increasingly acknowledged by industry and regulatory bodies.

Factors that contribute to potential hazards in foods include improper agricultural practices; poor hygiene at any stage of the food chain; lack of preventive controls in food production, processing or preparation operations; misuse of chemicals or food additives; use of contaminated raw materials, ingredients or water; inadequate or improper storage; chemical contaminants, including biological toxins; food fraud and economically motivated adulteration; etc.

An effective way to stop food contamination completely, F&B companies can significantly lower the risk with an effective food traceability system. While everyone in the industry is responsible in ensuring that food products are safe for public consumption, a comprehensive food traceability system will provide trust amongst the people

The traceability of the food sector has become a priority. It is essential to provide transparency and security to consumers who are demanding healthier products with a higher quality and the best nutritional characteristics. But it is also important for producers, because it ensures the quality of the raw material which is introduced into the food chain, allowing certification and accreditation of

their products, quickly locating problematic items, and implementing control systems, preventing fraud and unfair competition between producers.

By using food traceability, businesses can identify any product's current location. Besides that, will be able to record, verify, and track each product's entire history through the supply chain. If an issue arises in supply chain, the tracking system enables tracing back the particular issue originated from.

Consumer Awareness

Data from WHO suggests that an estimated 600 million fall ill after eating contaminated food every year. Of this, a whopping 420,000 people die every year due to food-related illnesses.

Since consumers cannot know in detail what processing steps are executed in the production of food and what ingredients or resources are used in these steps, they want to be assured that food products are safe, healthy, sustainable, and of high and consistent quality.

Consumers care about what they eat, how their food is produced, and the impact that food production and consumption have on the environment and society. Consumers' concerns about the methods of food production (organic, inorganic, and genetically modified) and the conditions under which the food is grown have also increased in the last decade.

Today, consumers are more concern about the actual product's nutrients facts and as well the whole process of the product. Therefore, every Food & Beverages manufactures should pay more attention on the information such as processing methods, packaging, transportation logistics, certificates & as well as quality of each ingredient.

Food traceability is increasingly becoming

an important aspect for building trust between food brands and their customers. This is especially true since most products are made up of ingredients that are sourced from all over the country, and often even span across countries. We have a global pantry, and no matter how strict our regulations and food safety norms, this widespread canvas makes it difficult for regulatory bodies to monitor each and every ingredient that lands up on our plate.

Global Food Trade

Globalisation of food production and distribution is resulting in increased complexity in managing food safety concerns. The dramatic increase in global trading and the complexity of supply chains has caused several issues concerning the authentication of food. With the rise of global products recalls, more regulations have been implemented to protect the end consumer than ever before.

Traceability started to play an important role in Food & Beverage industry. The global food supply chain today has evolved into a tangled web as companies seek to enhance their capabilities to feed the world's growing population.

Frequent food alerts and consequent major food recalls, deeply impacting consumer confidence and inviting increased regulatory oversight with stipulation of stringent requirements for food businesses. An essential requirement under food safety is the need for implementing 'farm to fork' traceability, which facilitates preventive and remedial measures to be undertaken in food safety regimes.

Traceability in India

A food traceability system allows brands to have complete visibility and control over their products at every stage of the supply chain. If an issue were to arise at any point of time, the brand can trace it back through the product's history and identify the specific glitch, taking corrective action before it is too late.

Since the Indian food industry caters to huge number of consumers in India as well as abroad, it becomes imperative to ensure safety in food supply chains. Inability to control supply and demand chains in an efficient manner may lead to making the food we eat a lot less secure than we would like to imagine.

The more unsettling fact is that our

food supply chain has grown so complex that it has become almost impossible for food producers to guarantee safety of their products. This makes consumers demand more and more information about the product and its journey in the supply chain, putting added responsibility on manufacturers and other food business operators to meet this consumer need.

This means that during an outbreak investigation, our ability to rapidly track and trace food is often impeded by insufficient data identifying a food as it moved through its supply chain. A modern, coordinated approach to traceability that can be used and understood throughout all stages of the food supply chain will go further to reduce foodborne illness, build consumer trust, and avoid overly-broad recalls.

Implementation of food traceability can be complex and involves many different aspects that affect each other. A number of problems and implementation hurdles can occur before, during, and after implementation of food traceability. Agencies must develop systems in coordination with the food industry to explore and evaluate methods and appropriate technologies for rapid and effective tracking and tracing of foods. ■

Committed to quality and reliability for more than 70 years, here in India and around the world.

T&S Brass and Bronze Works is proud to offer a complete selection of durable, high-quality products designed to help foodservice facilities save water and energy for years to come.



RELIABILITY BUILT IN™
www.tsbrass.com



Rajesh Chowdhury — Head of Business Development -
India and Sub-Continent
PH +91-9-620-777757 rchowdhury@tsbrass.com





Food Hygiene has Become Foremost Priority Post COVID

By Manish Aggarwal

One of the most desirable consequences of Covid-19 has been the increased all-round consciousness for hygiene. And among several types of hygiene such as personal hygiene, environmental hygiene etc which impact our day-to-day lives, food hygiene has naturally emerged as a major issue for regulators, consumers and above all, food manufacturers and companies. The constant need to be watchful of what is ingested or goes inside of our bodies can never be exaggerated enough. The recent pandemic has only further highlighted the need for making food hygiene a priority for all.

What makes for Unhygienic Food: Unpackaged Food an Invitation to Disaster

There has been repeated reporting of how the open and unpackaged food sold in the streets fashionably called street food has in a way been responsible for unsafe and unhygienic food consumption in the country. Particularly in these times of Covid, if the food maker doesn't maintain personal hygiene, wears masks and gloves and keeps sufficient physical distance from fellow workers, the food prepared is highly risky to consume. The unhygienic and unsafe food leads to a vicious cycle of disease and sickness particularly impacting the elderly, the sick and the children, adding to the already high burden of disease pervading in the country.

Food-borne Diseases has an Economic Cost

Yet, the rise in outbreak of food borne diseases and safety cases has continued to be reported periodically from different parts of the country. In fact, unsafe food and water have been cited to be the biggest cause of preventable infection in India. Not



pursuing basic food safety practices such as wearing an apron, accessing and using tap water, using soap for cleaning utensils, and storing food in proper refrigerated facilities is an invitation to food-borne diseases. This also has an economic cost. It has been estimated that food-borne diseases cost the country a whopping \$15 billion.

The Numbers are Far too Scary to Ignore

In India, food-borne diseases (FBD) lead to 120,000 deaths each year imposing a burden of over 8 million Disability Adjusted Life Years (DALYs). In fact, little children under 5 years are at 40% more risk with around 30,000 deaths each year. These are frightening figures which are only expected to rise further in the coming years.

The Covid-driven Exigency

These ongoing measures were given a new impetus when Covid-19 showed up resulting in a new set of guidelines. In addition to the existing food safety protocols, the food businesses were directed to ensure that food handlers and workers are made aware of the symptoms of the virus, the risks emanating from it as well as the good practices to circumvent those risks. Training programmes on risk factors, safe

food handling, social distancing and other protective behaviours such as wearing of face mask, hand washing with soap or using alcohol-based sanitizers were made mandatory.

In addition, food premises including areas of food establishment such as preparation, storage and packing areas, equipment and containers besides toilets and washrooms were to be periodically sanitized without fail. There should be limited food workers/handlers in a kitchen or areas of food preparation, packaging etc with each worker strictly maintaining personal/social distancing. Further, the personnel involved in delivery, transport and distribution mechanisms must also rigorously observe Covid-related social distancing and personal hygiene norms and practices.

Therefore, for food to be finally consumed in a safe and hygienic manner, it must become high priority for the entire ecosystem of food manufacturing, distribution and consumption. From hospitality and restaurants to food manufacturers and food vendors to food handlers and finally the food-consuming individual, everyone needs to be aware of and engage in hygienic food practices.

"A man is what he eats," a German philosopher had once said. Good food hygiene practices not only reduce morbidity and mortality but also relieve pressure on the already overburdened health infrastructure and services in the country. And even more importantly, by keeping more people healthy and thereby raising the quality of human capital, the much-touted demographic dividend in the country can truly be tapped.

The author is Director at Director, Bikanervala Foods Pvt. Ltd. (Bikano)



**INDIA INTERNATIONAL
HOSPITALITY EXPO**
INDIA EXPO CENTRE & MART

*India's Biggest Hospitality
and F&B Show*

**AUG 04-07
2021**

"We had received a very positive response from our domestic as well as International Exhibitors and Visitors during IHE 18 and 19. While we went virtual with IHE 20, at IHE 21, we're aiming to create India International Hospitality Expo into Asia's Biggest Hospitality and F&B Show. I thank everyone who has supported us in our journey."

DR. RAKESH KUMAR (Chairman, IEML)



1000 EXHIBITORS

30,000 VISITORS

38,000 SQM SPACE

BOOK NOW WWW.IHEXPO.COM

AN EVENT BY INDIA EXPOSITION MART LIMITED
India Exposition Mart Ltd.
Plot No. 23 25 & 27 - 29, Knowledge Park - II
Gautam Budh Nagar, Greater Noida - 201306 Delhi NCR, India

For queries, please contact
info@ihexpo.com/ +91120 2328011-20/ +91 9717798063



Versatile Tableware

METINOX India is a dynamic company manufacturing and distributing kitchenware and tableware. The company is headquartered in Delhi with modern manufacturing and distribution facility. METINOX created new standards in quality and design in its products development. The extensive range of kitchenware and tableware is created to the satisfaction, effectiveness, durability and versatility for the users. The company values customer's expectations and deliver on a timely basis. Being present pan India, METINOX offers its comprehensive range at viable price range. METINOX optimizes product range,



design and service to keep pace with the times thereby achieving excellence. The company maintains and follows quality managements to make ideal products. Internal quality control team equipped with advance testing facilities deliver quality products. It regularly performs assessments on products and its standards. The research team is always remain well versed with market conditions and trends, to upgrade its range. It has state-of-the-art manufacturing facilities, CAD software, and CNC machine workshops, advanced production process, and experienced engineers & technicians. The company keep investing in R&D and frequently updates the designs defining new trends.

The products are manufactured with high grade stainless steel and the range of cutlery and kitchen tools is synonymous with quality, durability, and class. The range includes cutleries, tableware & serves ware, kitchenware, turners and spatulas, tongs, chef helpers, wire ware, hotel ware.

METINOX India
metinoxindia@gmail.com

Bakery Equipments by Jendah

Based in Taiwan and founded in the mid 1970's as a bakery oven factory, JENDAH has engaged in design, manufacture, and sale of bakery, commercial foodservice and food processing equipment for more than 40+ years.

Developed from a local factory to an international company, JENDAH has partnered with a number of leading food equipment providers to sell and support its products primarily in UK, South Africa, Singapore, Malaysia, India and Middle East.

Today, JENDAH is renowned for high quality products and provide a wide selection of quality solutions manufacturing a variety of cooking, baking, and thermal solutions such as deck ovens, rotary rack oven, pizza ovens, commercial waffle makers, proofer / prover, rotisseries and countertop baking machines for the bakery, foodservice operations, restaurant, pizza shop, and hypermarket worldwide.

The range of ovens cooks and bakes faster, producing consistent results without compromising quality. In India they are patronised by Oberoi, Trident, The Lalit, Pullman, Sheraton, Hyatt and Pizza Hut to name a few. The products are made available in India by Mod Kitchen.



The products are manufactured focusing on providing low cost components and equipment while securing product functionality and quality. Detailed thermal analysis and validation services are powered to design the most precise and suitable products.

Mod Kitchen Equipment Pvt. Ltd.
modequipment@yahoo.co.uk

Commercial Kitchen & Service Solutions

Dristi Kitchen Solutions manufactures food service equipment, serving hotels, foodservice industry and institutions. The company provides one stop solution for projects from planning of the kitchen to manufacturing and installation of equipment. The products are manufactures under strict quality control offering reliability and innovation with service assured round the clock. Dristi offers complete range of Indian & Imported food service equipment catering to the tailor made needs of the customer. The complete range includes Cooking Range, Dishwasher, Refrigerator, Cold room, Baking Oven & Combi Oven, Coffee machine, Hoods Bain Maire, Bulk Cooking System, Bar Items and



Pantry Item. In the recent year, the company introduced modern and sophisticated kitchen equipment for bulk and quick food preparation of wide variety. The reason for the sound functioning and impeccable reputation of the group is due to the perseverance of its management and its dedication to the correct service and attention to Quality. The company is ISO 9001: 2008 registered. Dristi has separate fully dedicated team for Installation, Testing and Commissioning. They are supplying equipment to Foods Chain, Restaurants, Supermarkets, Hospitals Industrial Canteen.

Dristi Kitchen Solutions
info@dristiindia.com



 CRM	 Cloud Kitchen	 Order Taking	 Call Centre
 3rd Party Orders	 Dispatch Tracking	 Feedback	 MIS



**DRIVING GROWTH
VIA TECHNOLOGY**

Your Partner of Choice



Mob: 9811780539 / 9711794194 Email: sales@rezol.in Web: www.rezol.in

 FRENCH COOK'S KNIFE WIDE	 BREAD KNIFE	 Remington KNIVES +91-9810023928 remingtonsteelarts@yahoo.com +91-9910017678 www.remingtonsteelarts.com	 CHEESE KNIFE	 CLEAVER
 PARING KNIFE	 PALLETTE SPATULA		 BUTCHER KNIFE WIDE	 DE-BONING KNIFE
 SLICING KNIFE	 BENT SPATULA		 SCRAPER	 PIZZA CUTTER

ADVERTISER'S INDEX

COMPANY	PAGE NO.	COMPANY	PAGE NO.
ARCHII	43	ITPO	01
CATERDESIGN CONSULTANT LLP	37	KPL INTERNATIONAL LIMITED	27
CHANDRA ENGINEERS	10	LOOMCRAFTS FURNITURE INDIA PVT. LTD.	17
CREMICA FOOD INDUSTRIES LTD.	FIC	METINOX INDIA	29
DHANJAL INDUSTRIES	23	MOD KITCHEN EQUIPMENTS PVT. LTD.	15
D K G SALES PVT. LTD.	21	MUNNILAL TANDOORS P. LTD.	09
EURO FOODS PVT. LTD.	43	PANASONIC APPLIANCES INDIA CO. LTD.	31
FAGOR INDUSTRIAL S. COOP.	11	RANS TECHNOCRATS INDIA PVT. LTD.	07
GPA CAPITAL FOODS PVT. LTD.	BIC	REMINGTON STEEL ARTS	55
GNOSCH FOODS PVT. LTD.	05	REZOL	55
HINDUSTAN REFRIGERATION STORES	33	STERLING SOLUTIONS	06
HOTREMAI	35	TS BRASS AND BRONZE WORKS PVT. LTD.	51
IFB INDUSTRIES LTD.	13	VEEBA FOOD SERVICES PVT. LTD.	BC
INDIA EXPOSITION MART LTD.	53	WINTERHALTER INDIA PVT. LTD.	25

Creating Empowered Teams!

Pradipt Sinha, Director of Food & Beverage, Crowne Plaza Today New Delhi Okhla



Pradipt Sinha has recently joined Crowne Plaza Today New Delhi Okhla as Director of Food & Beverage. With an experience of over 18 years as a chef, Pradipt excels in various cuisines with specialty in Italian and Mediterranean. In the year 2018, he was awarded as The Chef of the Year by FHRAI.

He possesses strong business acumen with a capability to execute a wide range of strategies to establish market presence and developing new streams for long-term revenue growth. He has extensive knowledge of menu engineering, problem resolution, revenue management, staff management, operations management and event curation.

In an exclusive interview with **Sharmila Chand**, he highlights his work philosophy and more....

What do you enjoy the most being a Food & Beverage Director?

The speed, precision and endurance of the kitchen area as well as guest area at the restaurants is what makes the job of Food & Beverage department most exciting. There is a different level of thrill when we are able to delight our anticipation filled guests with our culinary masterpieces, exceptional services standards and unique dining experiences and then receive appreciation in the form of reviews and feedback. No two days are same in this job which creates an opportunity to learn every single day. With the advent of social media and evolving guest preferences, we keep striving to create something new every time that can entice them.

Personally, I enjoy communicating with the guests to offer them best experience, creating strategies for better sales and marketing and building a passionate team who believes in the winning culture of IHG.

What kind of challenges you face?

The role of a Director of Food and Beverage is a 24x7 job where we strive to curate wow experiences for our guests. With mushrooming of standalone restaurants in the vicinity, price wars, reduced seating capacity due to such extraordinary times, evolving guest preferences, high attrition rates, it is very important to foresee these challenges on time and action accordingly. However, I see these challenges as an opportunity to

renovate and reinvent our ideas to create positive word of mouth for our services.

What kind of pressures you encounter at work?

There is a constant urge to be a trend setter in the market when it comes to food and beverage. Especially, with the unprecedented popularity of social media, it is extremely important to gauge the interest of our guests. Additionally, there is lot of focus on cleanliness and safety during such extraordinary times. As a team leader, I also focus on resource optimization, manpower handling, team motivation and revenue management. These are the key areas which need 24x7 attention.

Any tips or insights you exercise to strengthen your team?

As a team head, I believe in encouraging and building mutual trust, respect, and cooperation amongst the team members. This builds empowered, passionate winning teams, which is the core value of IHG.

What is the USP of your F&B outlets?

If you are looking to experience the 'world cuisine on your plate' then Edesia, our multi-cuisine restaurant boasts of one of the largest buffets in the city (along with ala-carte experience). The live buzz of show kitchen, the adjoining alfresco and poolside area, the private dining areas and curated dining

experience options make it a must visit option.

'ChaoBella' boasts of world's two most popular cuisines- Italian and Chinese being served under one roof. If you are looking for the best coffee, desserts and savouries then 'French Heart', our patisserie is the place to be while hop on to our 'Copper Bar' for In-House Wine Cellar for invigorating evenings.

With our IHG Ways of Clean protocols, we have implemented enhanced cleanliness protocols and sanitization measures to ensure guest and colleague safety. This includes- revamped floor and table layout, QR code based menus, mandatory gloves and masks for the colleagues, assisted buffet services and many more.

What is your working philosophy?

I believe in leading by example. Instead of focusing on short-term results, I emphasize on mid to long term goals. This is what makes a bigger difference.

What is your take on the present pandemic times?

Ensuring that safety standards are upheld in the outlets, to maintain high level of trust that consumers have in food and services

Being innovative and creative with experiences and offerings

Focus on resource optimization and sustainability

Taking calculative risks for market penetration and alternate revenue streams.



Pulses, Besan, Maida, Sooji, Dalia, Poha & Rice



मन पशव्द स्वाद
रहे हमेशा याद



GPA CAPITAL FOODS PVT. LTD.

Ph.: 011-47820000 (10 Line) | Email: agropure@agropure.net

Website: www.agropure.net



We add flavour to your business.

Whether you are a restaurant, a fast food outlet, a catering service or a bakery serving cuisines from around the world, choose from our range of quality products and get the taste of success.

Mayonnaise | Ketchup, Sauces & Dips | Pizza & Pasta Sauces

Salad Dressings & Emulsions | Mustards | Gravies | Ganache, Fillings & Icings

Fruit & Chocolate Toppings | Sugar Based Syrups | Flavoured Syrups

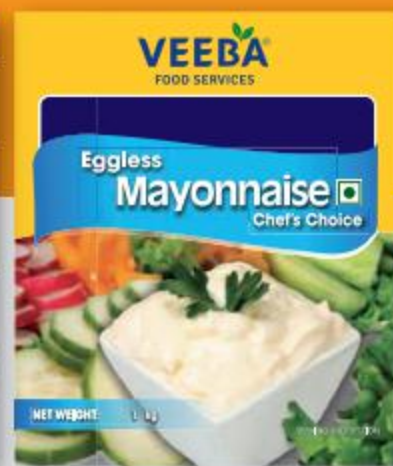

For business enquiries contact: VEEBA FOOD SERVICES PRIVATE LIMITED. Office No. 101, 1st Floor, Pegasus One (Inside IBIS Hotel Complex) Golf Course Road, Sector 53, Gurugram, Haryana 122002 | T: +0124 4653250 | www.veeba.in